

Safe, quick and reliable

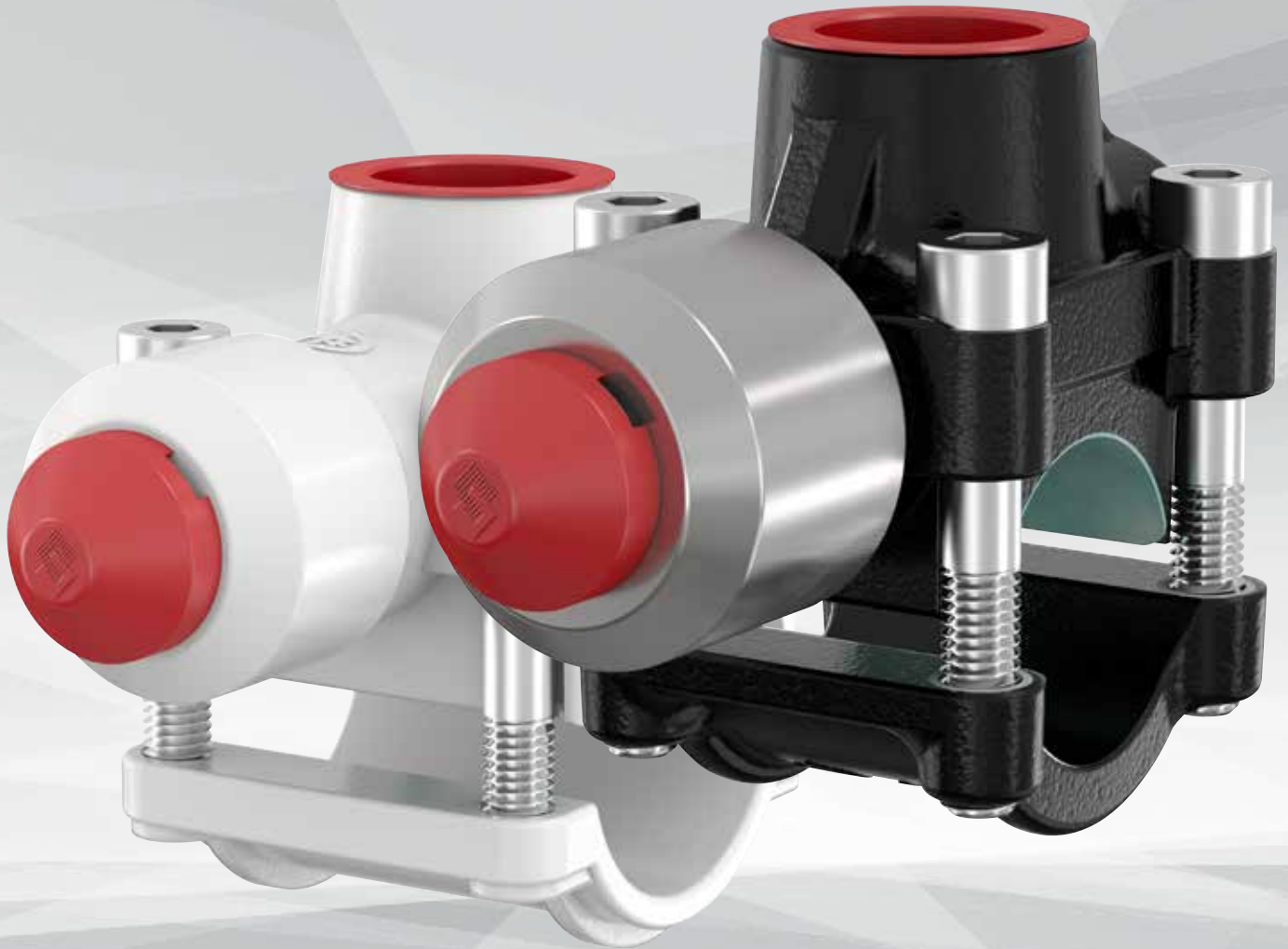

T-plus

Create branches whilst the system is still in operation

Lowers the risk of defects and saves installation time and costs

- **Draining is not necessary, so no air and dirt cannot get into the system**
- **A perfect branch every time due to the trigger**
- **Easy to create a branch, even where space is restricted**
- **Optimum pipe seal**
- **Anti-corrosion coating**
- **Simple preparatory installation with click-in nuts (on models from 1½")**

Branches can be made much easier

The expansion, conversion or overhaul of existing systems often leads to problems. Under normal circumstances the system must be taken out of operation in order to create a branch to drain off water or to freeze the water in the pipelines. After all, you can't just make holes in pressurised pipelines with water flowing through them. However, bringing the production process to a standstill is time-consuming, costly and thus anything but convenient.



What sort of consequences could this have?
The traditional way of creating branches means suspending the production process.

And that ultimately means:

- Air and dirt getting into the system.
- Damage to components.
- Resistance and failures in the system.
- A negative impact on performance in the production process.
- A shorter service life for the system.
- A greater chance of sweating.
- Greater energy consumption and, accordingly, costs.

An irritating and costly situation

Having to drain and refill a system gives oxygen a chance to get into the system. As steel oxidises when it comes into contact with oxygen this is something to be avoided, as it gives rise to corrosion. This, in turn, produces magnetite, which causes problems with pumps, heat exchangers, three-way valves, pipes, radiators and heat sensors. This has an adverse effect on performance, causes failures and reduces the service life of the system. Making holes in pipes with frozen water is no better. This leads to dirt in the system, in the form of swarf. In addition, traditional T-pieces cannot always fit properly to pipes with roughness, increasing the risk of leaks. In short, traditional shut-off methods generally mean inconvenience. Something that nobody wants.

The right solution

Creating a branch while the system is in operation

Flamco offers the solution with the innovative T-plus. Specially designed to create perfect branches quickly and easily, whilst the system remains in operation. The T-plus saves installation time and costs, plus it has a positive impact on the service life of a system. All this is down to the fact that the system doesn't need to be drained and re-filled; nor does the water need to be frozen.

That means that no air or dirt can get into the system, which could lead to malfunctions or defects. Another benefit is the security offered by having a perfect branch due to the smart cutting mechanism (the trigger). Even where space is restricted! Moreover, the gasket ensures that there is an optimum seal so that there is no chance of leakage.

An essential product for the expansion, conversion or overhaul of an existing system. So even for systems that operate around the clock that are essential for processes.



Major advantages

- Saves installation time and costs.
- Create branches while the system is still in operation.
- Draining is not necessary, so no air and dirt cannot get into the system.
- A perfect branch every time due to the trigger.
- Easy to create a branch, even where space is restricted.
- Optimum pipe seal.
- Anti-corrosion coating.
- Simple preparatory installation with click-in nuts (on models from 1½").

Ground-breaking technology

The new standard

The innovative technique that marks out the T-plus is the result of sound research. The design is unique and responds precisely to the requirements of installers and their customers. And it has a number of ground-breaking and innovative features. The combination of a plunger, striking pin and a trigger sets the new standard in the creation of branches for systems in operation.

Installers can make a branch in the blink of an eye in systems that are still operational. So these technical interventions cause no disruption to organisations and those organisations will be less frequently confronted with problems in future.

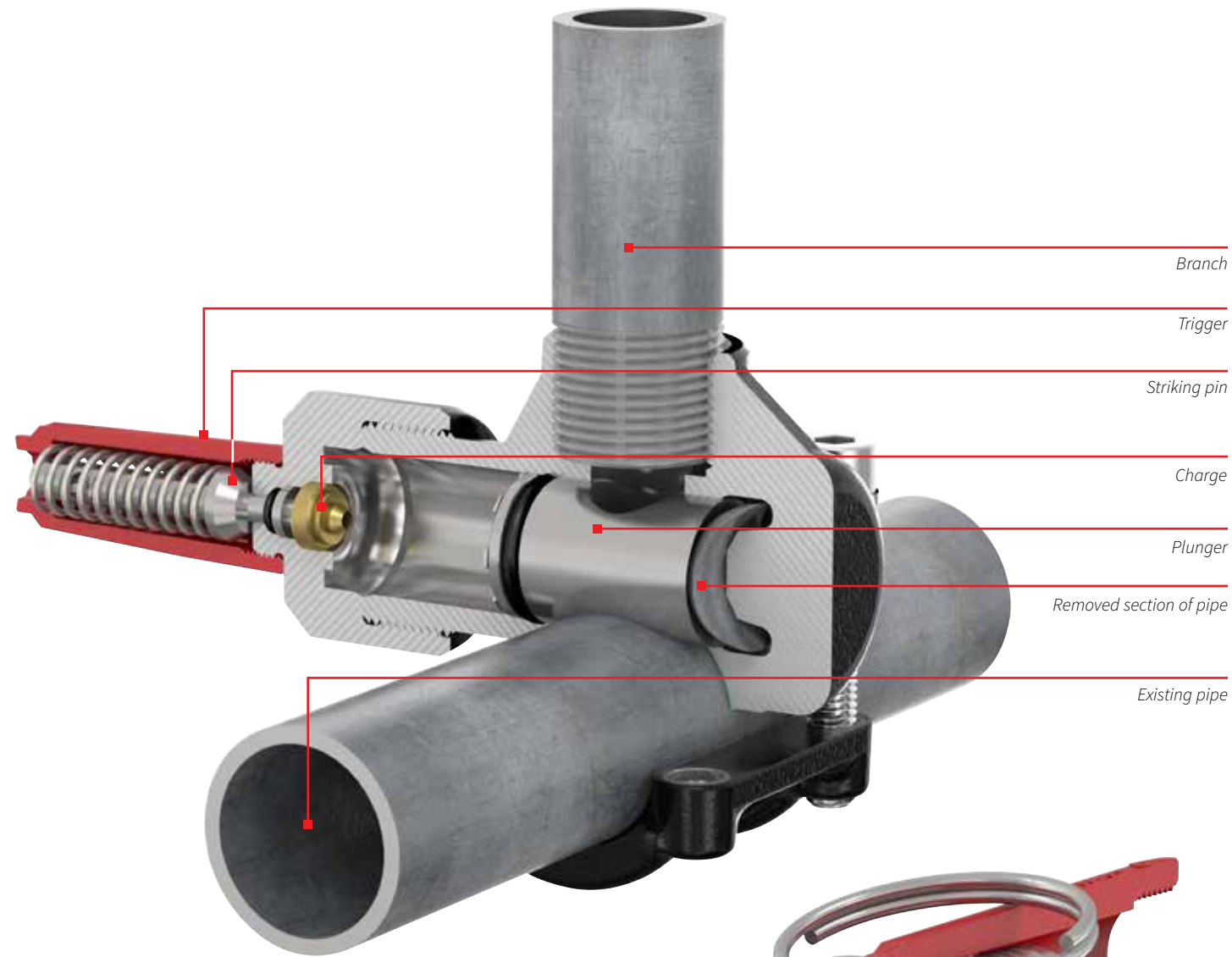

Trigger ensures perfection

The new branching mechanism (the trigger) means perfect installation everywhere, every time. Once the pin is removed, the charge ignites and the striking pin shoots straight forward. This makes a clean cut in the pipe creating the branch. This makes it possible to make branches even where there is little available space. There is no need for a hammer any more

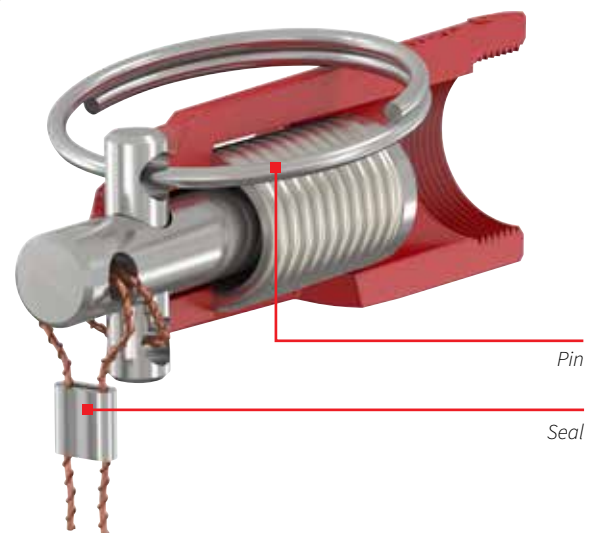

Efficient operation and easy installation

Installed in the blink of an eye

We are always looking for solutions that achieve the best solution in the least time for our installers and their customers. Using well-considered research and extensive testing we have reached the most efficient solution available.

With the T-plus, the installer need only carry out a few simple actions. The mechanism makes sure that a perfect branch is created.

How it works

This is how easy it is to use the T-plus

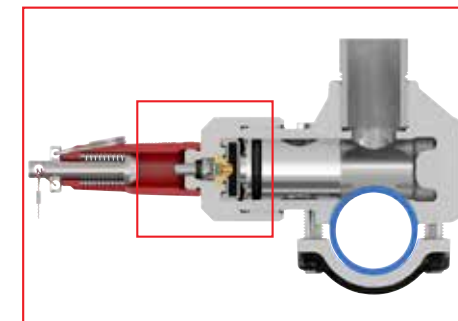

Plunger
There is a plunger in the housing of the T-plus.

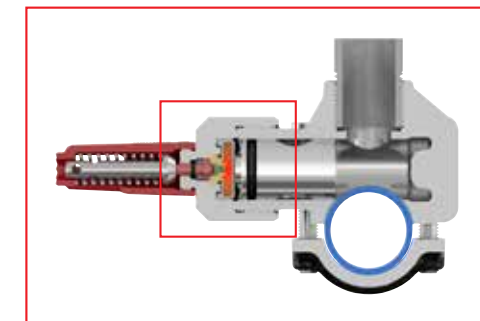

Ignition
Once the pin has been removed, the striking pin ignites the charge.

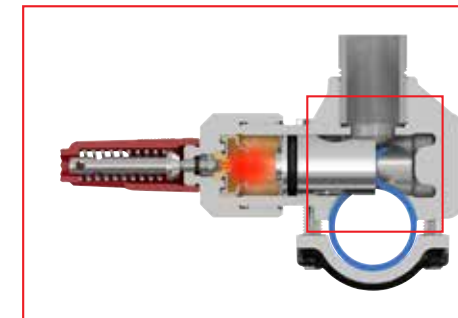

Cutting open the pipe
This builds up gas pressure which pushes the plunger and partially cuts open the pipe.

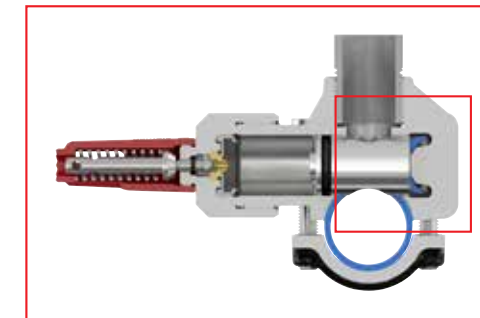

Removed section of pipe
The Flamco T-plus housing retains the removed section of pipe, so it cannot get back into the pipe.

Installation

We at Flamco really like to make things easy for installers. That is also the reason that we developed a new mechanism for making the perfect branch in just four steps.

No matter how small the available space is, installers can always deliver optimum quality with the T-plus. Creating a branch has never been easier.



Attach the T-plus to the pipe and secure with four bolts. Models from 1½" are supplied with click-in nuts; the bolt is clicked in, then screwed into place.



Tighten the bolts crossways. Use the tightening torque specified in the instruction manual. Connect the branch. Make sure there is no water in the branch when the T-plus is activated.

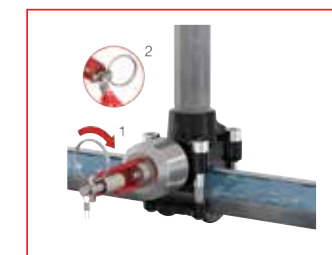

Twist the trigger on the T-plus. Position the ring in the most comfortable direction for you to pull (1). Cut through the seal (2).



Pull the pin (3). This makes a clean cut in the pipe, creating the branch. And that's all there is to it!

The complete range

Wide product range

In order to be able to supply the full spectrum, we have put together an extensive product range. From varieties for central heating, cooling, sanitary, fire extinguishing and solar installations to large-scale industrial installations, such as a compressed-air installation.

The T-plus is available in various pipe diameters. The patented technology is the same in all variants. Models from 1 1/2" are supplied with click-in nuts for simple preparatory installation.

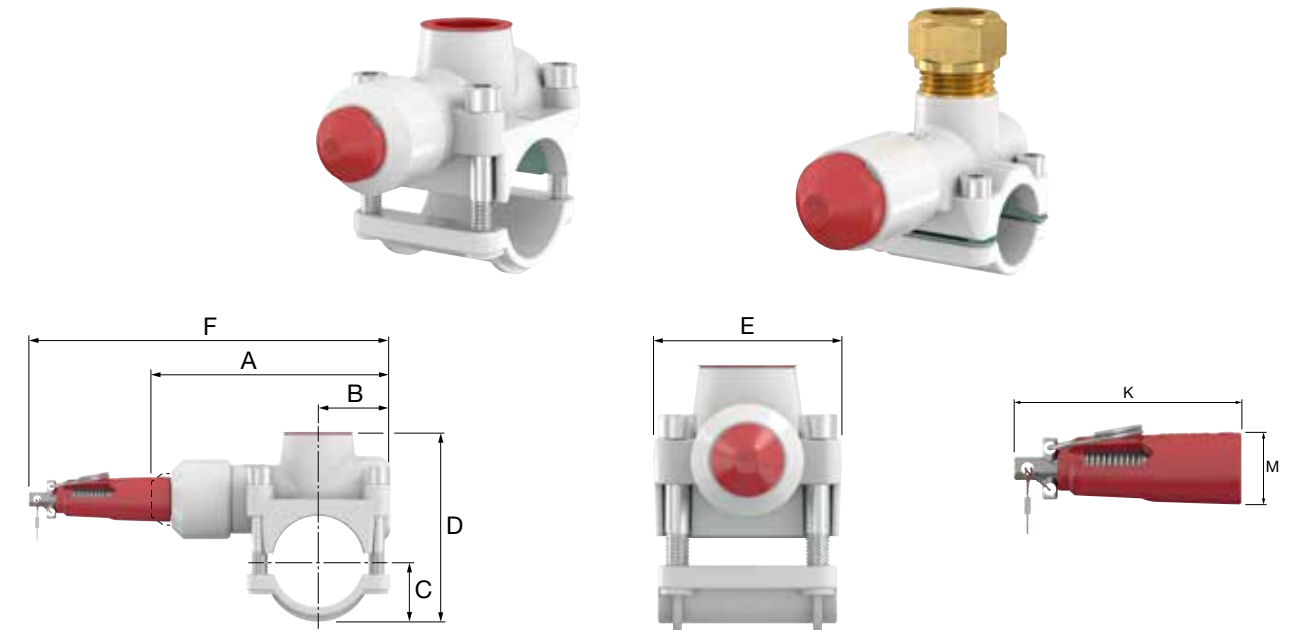
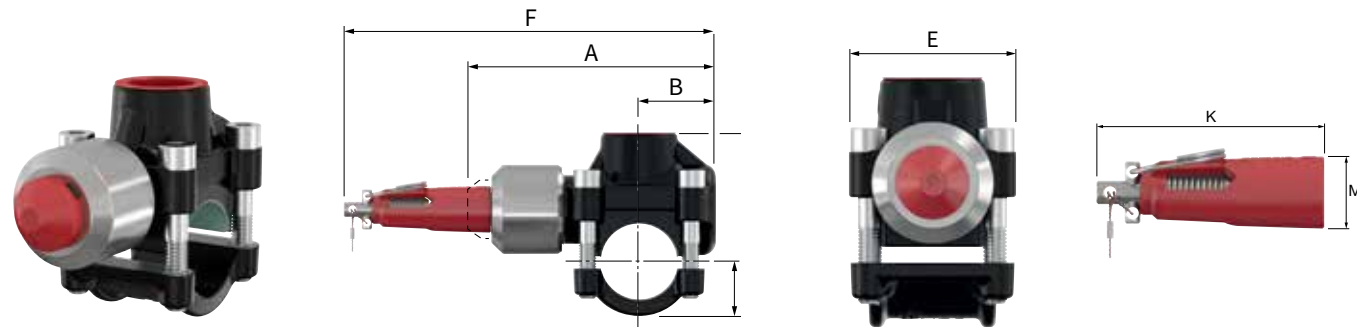

T-plus, cast iron

- Maximum working pressure: 25 bar.
- Maximum permissible temperature: 130 °C.

Type	Ø Pipe		Branch connection	Permissible wall thickness (s)		Torque [Nm]	📦	Order code
	Nom.	Ext. [mm]		Min. [mm]	Max. [mm]			
T-plus DN 15 x Rp 1/2	1/2"	21.3	Rp 1/2"	2.0	3.25	16	1	90615
T-plus DN 20 x Rp 1/2	3/4"	26.9	Rp 1/2"	2.0	3.25	16	1	90620
T-plus DN 25 x Rp 3/4	1"	33.7	Rp 3/4"	2.0	4.05	16	1	90626
T-plus DN 32 x Rp 1	1 1/4"	42.4	Rp 1"	2.0	4.05	16	1	90632
T-plus DN 40 x Rp 1 1/4	1 1/2"	48.3	Rp 1 1/4"	2.3	4.05	30	1	90640
T-plus DN 50 x Rp 1 1/4	2"	60.3	Rp 1 1/4"	2.3	4.50	30	1	90650
T-plus DN 65 x Rp 1 1/4	2 1/2"	76.1	Rp 1 1/4"	2.6	4.50	30	1	90665
T-plus DN 80 x Rp 1 1/4	3"	88.9	Rp 1 1/4"	2.9	5.00	30	1	90680



T-plus, cast iron - Dimensions

Type	Dimensions							
	A [mm]	B [mm]	C [mm]	D [mm]	E [mm]	F* [mm]	K [mm]	M [mm]
T-plus DN 15 x Rp 1/2	100	28	19	67	47	153	66	21
T-plus DN 20 x Rp 1/2	113	34	21	77	50	166	66	21
T-plus DN 25 x Rp 3/4	115	35	25	83	56	168	66	21
T-plus DN 32 x Rp 1	130	38	29	102	69	183	66	21
T-plus DN 40 x Rp 1 1/4	165	55	35	123	83	218	66	21
T-plus DN 50 x Rp 1 1/4	167	55	43	136	83	220	66	21
T-plus DN 65 x Rp 1 1/4	190	66	52	153	83	243	66	21
T-plus DN 80 x Rp 1 1/4	190	66	58	168	83	243	66	21

* Take 13 mm extra into account to be able to remove the trigger after creating the branch.

T-plus, brass

- Maximum working pressure: 16 bar.
- Maximum permissible temperature: 130 °C.

Type	Ø Pipe external [mm]	Branch connection	Suitable for			Max. permissible wall thickness (s)			Torque [Nm]	📦	Order code
			Thin wall steel	Copper	Stainless steel	Thin wall steel [mm]	Copper [mm]	Stainless steel [mm]			
T-plus 14 x G 1/2 M	14	G 1/2" M	-	✓	-	-	1.25	-	6	1	90514
T-plus 15 x G 1/2 M	15	G 1/2" M	✓	✓	✓	1,25	1.25	1.00	6	1	90515
T-plus 16 x G 1/2 M	16	G 1/2" M	-	✓	-	-	1.25	-	6	1	90516
T-plus 18 x G 1/2 M	18	G 1/2" M	✓	✓	✓	1,25	1.25	1.00	6	1	90518
T-plus 22 x G 1/2 M*	22	G 1/2" M	✓	✓	✓	1,50	1.25	1.25	6	1	90522
T-plus 28 x Rp 3/4	28	Rp 3/4"	✓	✓	✓	1,50	1.50	1.25	10	1	90528
T-plus 35 x Rp 3/4	35	Rp 3/4"	✓	✓	✓	1,50	1.50	1.50	10	1	90535
T-plus 42 x Rp 3/4	42	Rp 3/4"	✓	✓	-	1,50	1.50	-	10	1	90542

* Complete with 15 mm compression connection



T-plus, brass - Dimensions

Type	Dimensions							
	A [mm]	B [mm]	C [mm]	D [mm]	E [mm]	F* [mm]	K [mm]	M [mm]
T-plus 14 x G 1/2 M	75	17	13	48	35	153	66	21
T-plus 15 x G 1/2 M	75	17	13	51	35	166	66	21
T-plus 16 x G 1/2 M	75	17	12	46	35	168	66	21
T-plus 18 x G 1/2 M	88	24	14	51	40	183	66	21
T-plus 22 x G 1/2 M	88	24	15	58	40	218	66	21
T-plus 28 x Rp 3/4	105	29	22	76	57	220	66	21
T-plus 35 x Rp 3/4	108	30	25	82	56	243	66	21
T-plus 42 x Rp 3/4	115	35	29	89	63	243	66	21

* Take 13 mm extra into account to be able to remove the trigger after creating the branch.

Selection

Selection tables

There are two types of T-plus available: a cast-iron version for thick-walled steel pipes and a brass version for copper pipes, thin-walled steel tubes, central heating pipes and stainless-steel pipes. The tables below show you the right type to choose for your application.

T-plus, cast iron

For thick wall steel tubes

Pressure-loss diagram (in the branch)

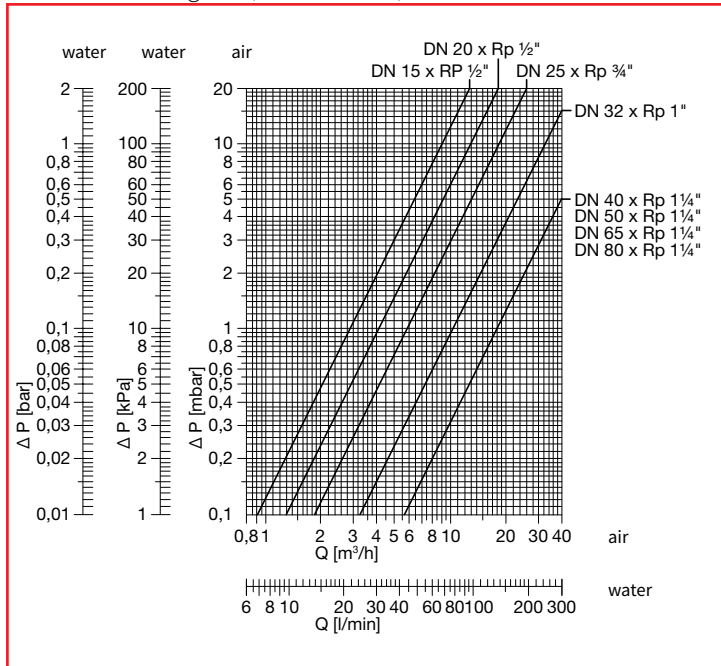

Medium: water/air
Testing with air under CETOP 3 RP/50 P conditions gave values that comply with the requirements for compressed-air installations.

Flow (in the branch)

Type	Water m³/h *	Water l/min *	Air m³/h **
T-plus DN 15 x Rp 1/2	3.9	65	2.9
T-plus DN 20 x Rp 1/2	6.0	100	4.1
T-plus DN 25 x Rp 3/4	7.8	130	6.0
T-plus DN 32 x Rp 1	15.0	250	10.5
T-plus DN 40 x Rp 1 1/4	24.6	410	18.2
T-plus DN 50 x Rp 1 1/4	24.6	410	18.2
T-plus DN 65 x Rp 1 1/4	24.6	410	18.2
T-plus DN 80 x Rp 1 1/4	24.6	410	18.2

* Flow at a pressure loss of 1 bar (100 kPa).
** Flow at a pressure loss of 1 mbar (0.1 kPa).

T-plus, brass

For copper, thin wall central heating and stainless steel tubes

Pressure-loss diagram (in the branch)

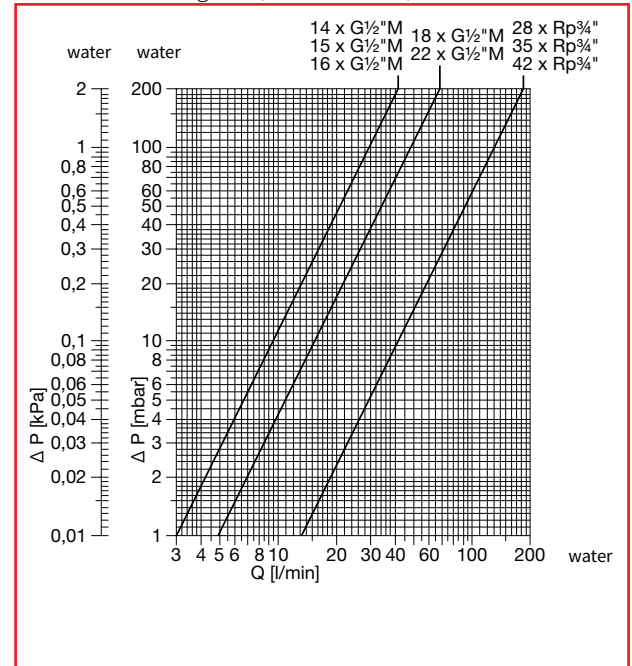

Medium: water

Flow (in the branch)

Type	Water m³/h *	Water l/min *
T-plus 14 x G 1/2 M	1.8	30
T-plus 15 x G 1/2 M	1.8	30
T-plus 16 x G 1/2 M	1.8	30
T-plus 18 x G 1/2 M	2.9	49
T-plus 22 x G 1/2 M	2.9	49
T-plus 28 x Rp 3/4	7.8	130
T-plus 35 x Rp 3/4	7.8	130
T-plus 42 x Rp 3/4	7.8	130

* Flow at a pressure loss of 1 bar (100 kPa).