

VARIOCON Universal Regulator Valve

simplex

With connection thread M 30 x 1.5



Only allow work on heating and domestic water systems to be performed by qualified personnel and in accordance with the respective applicable regulations, guidelines and rules of engineering.

**Refer in particular to:**

DIN 18380 Heating systems and central hot water supply systems

VDI 2035 Scale formation in domestic water heating systems and water heating systems

BGV German Professional Association Regulations (accident prevention regulations)

(DIN = The German Institute for Standardisation

VDI = Association of German Engineers)



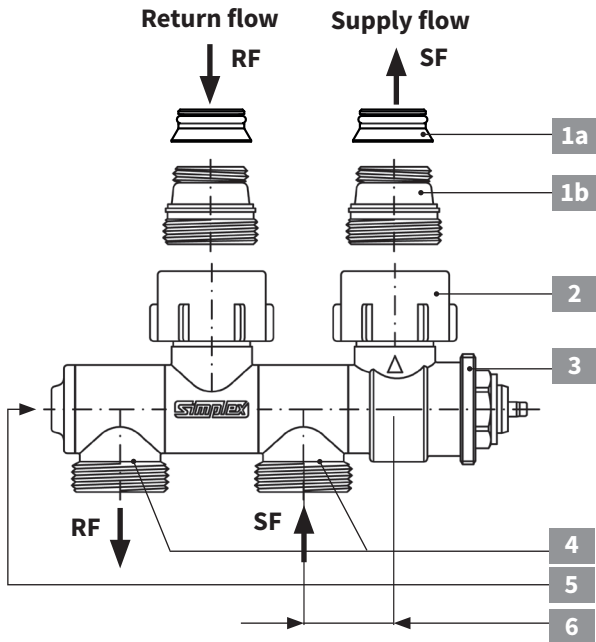

- 1a** Cone inserts for radiators with 3/4" male thread (Euro taper) - push into radiator connection, or
- 1b** Connection nipple (flat sealing) for radiators with 1/2" female thread
- 2** Union nut 3/4"
- 3** Connection thread M 30 x 1.5 (for thermostatic head)
- 4** Pivoting connection segments with 3/4" male thread (Euro taper)
- 5** Shut-off spindle, return flow (Allen key 4 mm)
- 6** Axial offset 25 mm

Presetting Values (at 2 K deviation)

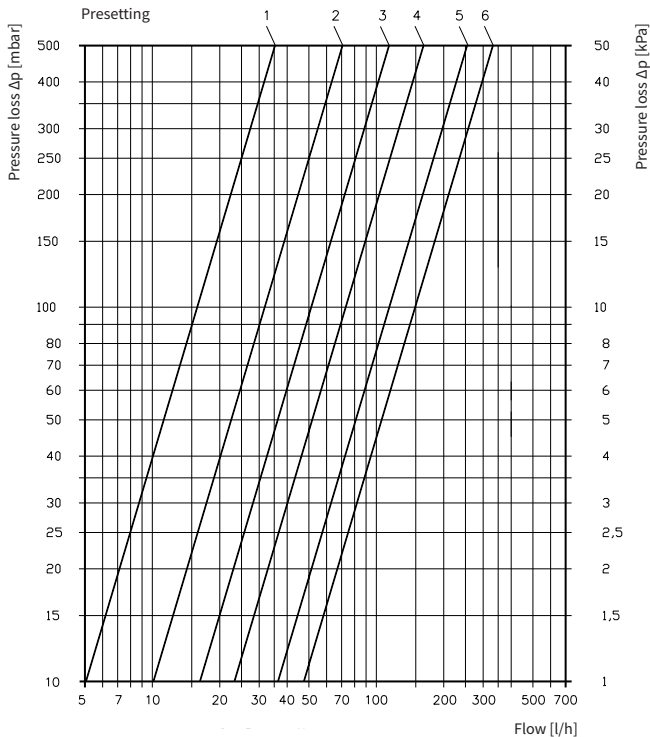

Presetting	k_V value [m^3/h] at deviation			k_{VS} value
	1 K	2 K	3 K	
6	0.25	0.47	0.63	1.00
5	0.22	0.36	0.41	0.46
4	0.17	0.23	0.24	0.25
3	0.14	0.16	0.16	0.17
2	0.09	0.10	0.10	0.10
1	0.05	0.05	0.05	0.05

Installation

- Pipework and radiator must be previously well flushed.
- For radiators with 1/2“ female thread, screw in the self-sealing nipples with Allen key 12 mm.
- For radiators with 3/4“ male thread, press in the enclosed cone inserts into the connections of the radiator.
- Build in the thermostat horizontally and freely accessible.
- Assemble as tension-free on the radiator with ribbed nuts 30 mm, wherein the supply flow must always be supported as lying on the valve side (refer to the arrow marking).
- Alignment of the pipework-side connections to wall or floor connection by rotating the supports. The connecting supports are prepared for compression adapters with 3/4“ Euro taper.
- Ensure correct connection of supply flow and return flow.
- Remove protective cap and assemble the thermostatic head for final assembly.

Presetting

- Attach the supplied presetting key on the valve block.
- Set the necessary kv-value - at the selected deviation according to the characteristic curves - by turning the setting disc on the valve and aligning the respective setting number on the point shaped marking on the housing.
- After each adjustment, the secure fit of the valve insert must be checked.
- To ensure that no disruptive plumbing noises result in partial load operation, do not select the differential pressure via the valve as too high.
- A valve authority between 0.3 and 0.7 ensures a safe operation.

The illustrations are symbolic and may differ from the respective product.
Errors and technical changes reserved.

03/2019