

# VSH SUPER Compression Fittings Metallic Sealed



**Simplex**

Member of Flamco

## Areas of application

- Suitable for domestic water systems according to DVGW W 534 and DIN 1988, pipe materials: Copper pipe DIN EN 1057 and stainless steel pipe DIN EN 10312, DVGW GW 541 dimensions 12 to 42 mm, certification no. DW-8511AQ2006
- Suitable for gas installations according to DVGW worksheet G 260/I the 2nd gas type, according to DIN 3387 (removable pipe connections for metal gas pipes / smooth pipe connectors) and in accordance with DVGW G 600, TRGI 2008, pipe material: Copper pipe according to DIN EN 1057 and DVGW GW 392, semi-hard (R250), dimensions 12 to 22 mm, certification no. NG-4502BL6101 (use support sleeve)
- According to DIN 1988 and DVGW worksheet G 600, TRGI 2008 VSH SUPER compression fitting made of brass may be installed under plaster.



## Important Installation Notice!

Under certain conditions brass components (including nuts, clamp rings of VSH SUPER compression fittings) can be affected by stress corrosion cracking. This special type of corrosion leads to component failure.

To prevent this, such systems must not be exposed to ammoniac or chlorinated environments (e.g. stables, swimming pools). Furthermore, no condensate should form on the fittings. Particularly in the areas where fittings and pipes are continuously cold must be fully and non-diffusively equipped with closed cell insulation to reliably prevent condensation. The insulation used and all other adhesives, additives and coatings have to be absolutely free of chlorine, ammoniac and nitrite.

If in doubt, a clearance certificate must be obtained from the manufacturer.

The prescribed processing instructions with information concerning the correct installation of the union nuts must be observed.

When using VSH SUPER compression fittings in gas systems, no oil or grease may be used to facilitate assembly. Danger of explosion! Only aids authorized in accordance with the relevant DVGW guidelines and with appropriate DVGW registration are permitted.

The reuse of a previously used fittings is only permitted with a new seal set.

# VSH SUPER Compression Fittings

## Approval

VSH SUPER compression fittings can be used in various size ranges for the following pipes:

- Stainless steel pipes according to DVGW worksheet GW 541 (DIN EN 10312)
- Copper pipes according to DIN EN 1057 (for soft copper pipes R220 support sleeves must be used)
- Carbon steel pipes according to DIN EN 10305
- Plastic pipes (PE / PEX) to DIN 8074 and DIN 8075 (use support sleeves)
- Cylindrical thread connections according to DIN 228-1
- Conical thread connections according to DIN EN 10226-1

Operating conditions*	Max. pressure	Max. temp.
Domestic installation (dimensiones 12 to 42 mm)	10 bar	95 °C
Heating installation (dimensiones 12 to 42 mm)	10 bar	120 °C
Gas according to DVGW worksheet G 260/1 the 2nd gas type, copper pipe (R250) (dimensiones 12 to 22 mm)	1 bar	- 20 °C to + 60 °C
Compressed air	7 bar	30 °C
Oil (dimensiones up to 28 mm)	10 bar	70 °C
Solar installation (dimensiones 12 to 28 mm)	10 bar	200 °C

# VSH SUPER Compression Fittings

## Function

The clamp ring sits on two conical holes in the housing and the union nut (see Fig. 1). The conical hole on the housing has a smaller angle than that of the union nut. With this design the tightening of the locking ring results in deformation of the housing first and then in the union nut. This prevents the pipe from turning during assembly. Fig. 2 shows the clamp ring connection after assembly. When the union nut is tightened as prescribed, the clamp fitting and pipe are permanently connected.

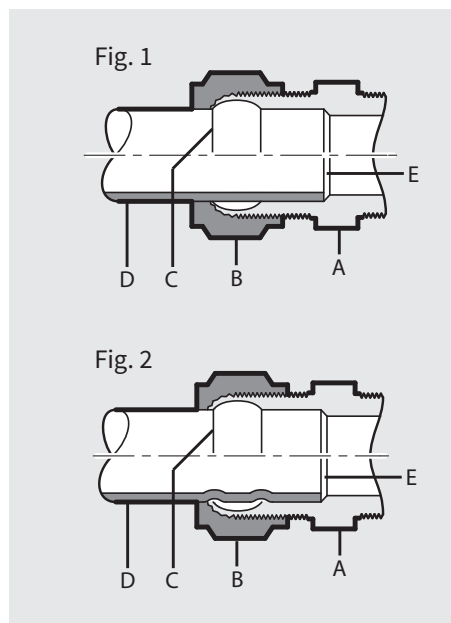

A = housing  
B = union nut  
C = clamp ring  
D = pipe  
E = abutting edge

## Installation instructions

- A. Cut pipe to length (saw or cut)
- B. Deburr pipe ends and check for scratches, impurities and deformations.
- C. Check for proper position of clamping ring on fitting. Slide pipe through clamp ring to the stop in the fitting. The clamp ring must be seated on the pipe as shown in Fig. 1.
- D. Tighten union nut by hand (it is recommended to apply a waterproof mark) and then tighten according to the prescribed number of revolutions in table 1.
- E. Then check the connection for leak-tightness (take local regulations for the media used into consideration).

If leaks are found after installation, disconnect the pipe and check for damages. Then tighten the union nut hand tight and retighten with the spanner 1/8 to 1/4 turn, since the clamp ring is already in a clamping position.

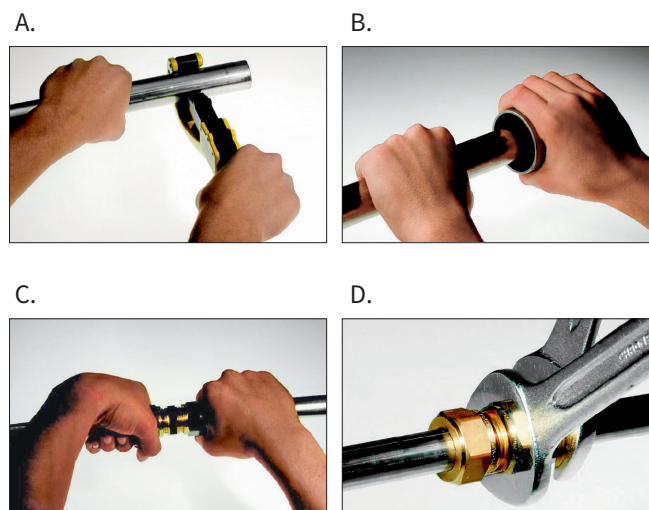

## Prescribed number of rotations for tightening

Dimensions Type of pipe	6 to 12 mm	15 to 28 mm	35 mm	42 mm	54 mm
Copper	1	1	3/4	3/4	3/4
Thin-walled steel/stainless steel	1	3/4	3/4	1/2	1/2
Plastic (PEX) with support sleeve	1 1/4	1 1/4	1 1/4	-	-

Table 1

**Notice: Over tightening the union nut may result in leaks or even breakage of the nut!**

# VSH SUPER Compression Fittings

## Remounting/multiple use of fittings

Existing connections can be removed and re-installed. The clamp ring fixed at its intended location is placed under tension when the union nut is tightened by hand. Then tighten 1/8 to 1/4 turn with a spanner.

The clamp ring can be removed by making an oblique saw cut (see Fig. 3), without damaging the pipe. Expand ring using a flat object and carefully removed it from the pipe.

## Installation information

In table 2 the insertion depths are listed for planning and pre-fabrication (see Fig. 4).

Fitting connection [ø mm]	Insertion depth A [mm]
6	13.5
8	14.5
10	16.5
12	18.5
15	21.5
16	22.5
18	22.5
20	22.5
22	23.0
28	23.5
35	30.0
42	35.5
54	39

Table 2

	12	15	22	28	35	42	54
—	0.1	0.1	0.1	0.1	0.1	0.1	0.1
⤿	-	0.5	0.6	0.7	1.2	-	-
└	0.5	0.5	0.8	0.8	1.2	1.4	1.8
⊥	0.1	0.1	0.2	0.2	0.2	0.2	0.2
⊥	0.5	0.5	0.8	0.8	1.2	1.4	1.8
+	-	0.5	0.8	0.8	1.2	-	-
+	-	0.1	0.1	0.2	0.2	-	-

Table 3

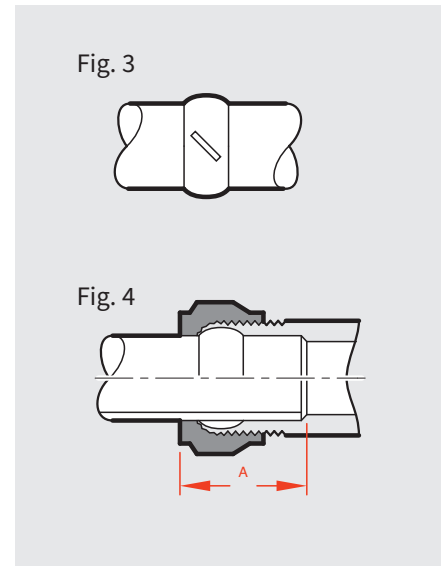

Tables 3 and 4 show the flow resistance of the fittings at a water velocity of 0.75 m/s expressed in the equivalent pipe length per meter. For reduction fittings the values in table 4 are to be added to the values in table 3.

	12	15	22	28
15	0.2	-	-	-
22	0.3	0.2	-	-
28	-	0.3	0.1	-
35	-	0.4	0.2	0.1

Table 4

All technical data is non-binding and does not represent guaranteed properties of the goods. The illustrations are symbolic and may differ from the respective product. Additional information is available upon request. It is the responsibility of the processor to select products in accordance with their properties. Installation instructions must be followed. Subject to technical amendments.