

Flamcomat MK-C G4 REMOTE



ENG Installation and operating instruction

Content

- 1. Liability..... 5**
- 2. Warranty..... 5**
- 3. Copyright..... 5**
- 4. General safety instructions 5**
 - 4.1 Warning symbols in this manual 5**
 - 4.2 Purpose and use of this manual 6**
 - 4.3 Qualifications required, assumptions 6**
 - 4.4 Staff qualification..... 7**
 - 4.5 Appropriate use 7**
 - 4.6 Incoming goods..... 7**
 - 4.7 Transportation, storage, unpacking..... 7**
 - 4.8 Operations room 8**
 - 4.9 Noise reduction..... 8**
 - 4.10 EMERGENCY-STOP / EMERGENCY-OFF 8**
 - 4.11 Personal protective equipment (PPE) 8**
 - 4.12 Exceeding permitted pressure / temperature levels 9**
 - 4.13 System water 9**
 - 4.14 Safeguards 9**
 - 4.15 External forces 9**
 - 4.16 Inspection prior to commissioning, maintenance and re-inspection 10**
 - 4.17 Electrical equipment inspections, routine inspection 10**
 - 4.18 Maintenance and repairs 10**
 - 4.19 Obvious misuse 11**
 - 4.20 Other hazards 11**
- 5. Product description..... 12**
 - 5.1 Operating principle MK compressor automat..... 12**
 - 5.2 Connectivity options 13**
 - 5.3 Markings 13**
 - 5.4 Type key compressor control unit 13**
 - 5.5 Component parts, vessels and connection assembly 14**
 - 5.6 Control unit 15**
- 6. Assembly 17**
 - 6.1 Setup 17**
 - 6.2 Vessel connection..... 17**
 - 6.3 Electrical Installation..... 19**
- 7. Commissioning..... 20**
 - 7.1 Initial commissioning 20**
 - 7.2 Commissioning, volume level and operating temperature 20**
 - 7.3 Overview menu..... 22**
 - 7.4 Clarification of menu icons, function and location 22**
 - 7.5 Malfunction messages 25**
 - 7.6 Restarting 26**

8. Maintenance.....	27
8.1 Maintenance Warnings.....	27
8.2 Maintenance schedule	27
8.3 Vessel draining/refilling.	28
9. Decommissioning, dismantling.....	28
10. Flamconnect Remote	28
Appendix 1. Technical data, information	30
Appendix 2. Technical data, specifications, hydraulic equipment	31
Appendix 3. Technical data, information, electrical equipment	32
Control unit, terminal plans	32

1. Liability

All technical specifications, data and instructions for executable actions and actions that must be executed contained herein are correct at time of publication. This information is the result of our current findings and experience to the best of our knowledge. We reserve the right to make technical changes subject to the future development of the Flamco product referred to in this publication. Hence no rights may be derived from technical data, descriptions and illustrations. Technical pictures, drawings and graphs do not necessarily correspond to the actual assemblies or parts as delivered. Drawings and pictures are not to scale and contain symbols for simplification.

2. Warranty

You can find the corresponding specifications in our [General Terms and Conditions](#).

3. Copyright

This manual must be used confidentially. It may be circulated among authorised personnel only. It must not be given to third parties. All documentation is protected by copyright. Distribution or other forms of reproduction of documents, even extracts, exploitation or notification of the contents hereof is not permitted, where not otherwise specified. Infringements are liable to prosecution and payment of compensation. We reserve the right to exercise all intellectual property rights.

4. General safety instructions

Disregard or lack of attention to the information and measures in this manual may pose a hazard to people, animals, the environment and tangible assets. Failure to observe the safety regulations and the neglect of other safety measures may lead to the lapse of liability for damages in the event of damage or loss.

Definitions

- **Operator:** A natural person or legal entity who is the owner of the product and uses the aforementioned product, or is nominated to use it, under the terms of a contractual agreement.
- **Principal:** The legally and commercially responsible party in the execution of construction projects. Legally and commercially liable client in the commission of building projects.
- **Responsible person:** The representative appointed to act by the main contractor or operator.
- **Qualified person (QP):** Any person whose professional training, experience and recent professional activity gives them the requisite professional knowledge. This implies that said person has knowledge derived from relevant national and internal safety regulations.

4.1 Warning symbols in this manual



Warning against hazardous electric current.

Disregarding this could put lives at risk, cause fires or trigger accidents, lead to component overload and damage, or prevent functionality.



Warning against the implications of errors and incorrect set-up conditions.

Disregarding this could lead to serious personal injury, to component overload and damage, or prevent functionality.



Caution! Dangerously high temperatures.

Failure to observe this caution may result in burns to the skin.



You are advised to wear eye protection.

Failure to observe this advice may result in eye injury.



Caution about transporting heavy objects.
Failure to observe this caution may endanger the safety of people in the immediate vicinity of the load.

4.2 Purpose and use of this manual

The following pages list the information, specifications, measures and technical data that allow the relevant personnel to use this product safely and for the intended purpose.

Responsible persons or those engaged by them carrying out the required services must read this manual attentively and understand it.

Such services include:

Storage, transportation, installation, electrical installation, commissioning and re-starting, operation, maintenance, inspection, repair and dismantling.

Where the product is to be used in plants/facilities which do not comply with harmonised European regulations and relevant technical rules and guidelines of professional associations for this field of application, the present document is purely for informative and reference purposes.

As this unit may be subject to unlimited inspection at all times, this manual must be kept in the immediate vicinity of the installed unit, at least within the confines of the operations room.

Installation classification 2 according to the Annex R of 60730-1.

4.3 Qualifications required, assumptions

All personnel must have the relevant qualifications to carry out the required services and be physically and psychologically capable. The area of responsibility, competence and supervision of personnel is the duty of the Operator.

Required service	Professional group example	Relevant qualifications example
Storage, transportation	Logistics, transport, warehousing	Transport and warehousing specialist
Assembly, disassembly, repairs, maintenance. Re-commissioning after adding or changing components. Inspection.	Installation and building services	HVAC specialist.
First commissioning of configured control unit (generic), re-commissioning after power cut, operation (work on the terminal and Flextronic control unit)		People with operations room clearance with knowledge gleaned from this guide.
Electrical installation	Electrical engineering	Specialist in electrical engineering/ installation
Initial and re-inspection of electrical systems		Qualified person (QP) with certification in Electrical Engineering
Inspection before commissioning and re-inspection of pressure equipment	Installation and building services engineering performed in the context of technical inspection.	Qualified Person (QP)

4.4 Staff qualification

Operating instructions are transferred by Flamco representatives or others assigned by them during delivery negotiations or on demand.

Training for the required services, installation, dismantling, commissioning, operation, inspection, maintenance and repair are part of the training / further education for service engineers of the Flamco branch offices or named service contractors.

These training courses cover information on required installation conditions, but not their implementation.

On-site services include transportation, the preparation of an operations room with the requisite foundation engineering to accommodate the system, and the requisite hydraulic and electrical connections, the electrical installation for the power source of the expansion automat and installation of the signal leads for the IT equipment.

4.5 Appropriate use

Sealed water-based heating and cooling systems in which temperature-induced changes in the volume of the system water (the heat transferring agent) can be absorbed and the required operating pressure is governed by a separate expansion automat.

Suitable and equipped for the operation in heat generating systems according to EN 12828, EN 12952, EN 12953. The Principal / Operator will need to consult with a notified body on additional safety measures.

Use in similar systems (e.g. heat transfer systems for process industry or technologically conditioned heat) may require special measures.

4.6 Incoming goods

The items delivered must be compared against the items listed on the shipping note and inspected for conformity. Unpacking, installation and commissioning may be started only once the product has been checked to conform with the intended use as stated in the order process and contract. Exceeding the permissible operating or design parameters may lead to malfunctioning, component damage and personal injury.

If not in line with conformity or if the delivery is incorrect in another way, the product must not be used.

4.7 Transportation, storage, unpacking



The equipment is delivered in packaging units in accordance with the contract specifications or the specifications required for certain modes of transport and climate zones. These units meet at least the requirements set out in the Flamco B.V. packaging directives. In accordance with these directives, expansion vessels must be transported horizontally and pump units upright; each packaged on throw-away pallets. If the packaging is suitable for use with hoisting gear, this will be indicated at the designated hoisting points.



Important note: Transport the packed goods as close as possible to the envisaged set-up location and make sure there is a horizontal, solid surface on which the goods can stand.



Note: Take all necessary precautions to ensure that the expansion vessel cannot topple over or wobble once it has been unpacked and removed from the pallet.

The goods may also be warehoused in their packaging. Once it has been removed from its packaging, the equipment must be put in position, observing standard safety procedures. Do not stack the equipment.

Use only permitted lifting gear and safe tools and wear the required personal protective equipment.

4.8 Operations room

Definition: room which meets the applicable European regulations, European and harmonised standards and relevant technical rules and guidelines of the professional associations for this field of application. For the use of the expansion automat as prescribed in this manual these rooms generally contain equipment for thermal generation and distribution, water heating/cooling and top-up, power source and distribution, such as measuring, control engineering, control technology and IT.

Access for unqualified and untrained persons must be restricted or forbidden.

The set-up location of the expansion automat must ensure that operation, service, maintenance, inspection, repair, installation and dismantling can be carried out unhindered and without danger. The floor of the set-up location for the expansion automat must be such that stability is guaranteed and maintained. Bear in mind that the maximum possible forces can be exerted from the net mass including the water volume. If stability cannot be guaranteed, there is a danger that the vessel will tip over or move and, as a consequence in addition to functional defects may lead to personal injury.

The ambient atmosphere must be free from conductive gases, high concentrations of dust and aggressive vapours. There is the risk of explosion if any combustible gases are present.

Flooded equipment must not be operated. If electrical equipment short circuits, persons or other beings in the water will be electrocuted. Furthermore, there is a danger of malfunction and partial or irreparable damage to individual components due to water saturation and corrosion.

4.9 Noise reduction

Installations should be constructed with noise-reduction measures in mind. Mechanical vibrations of the assembly (Module framework, pipework) in particular can be dampened by using insulation between contact surfaces.

4.10 EMERGENCY-STOP / EMERGENCY-OFF

To conform with directive 2006/42/EG an EMERGENCY-STOP facility is to be made available during installation. Preferably, use a grounded wall socket for the power supply to the unit. The socket must stay accessible. If the unit is directly connected to the power supply, make sure the power supply line is provided with

- a high-sensitivity differential switch (30mA) (residual current device RCD)
- a mains isolator switch with a contact gap of at least 3 mm.

When additional security measures with EMERGENCY-OFF devices are required according to the design and operation of the heat generator, these are to be installed on-site.

4.11 Personal protective equipment (PPE)

PPE must be used when carrying out potentially dangerous work and other activities (e.g. welding), in order to prevent or minimise the risk of personal injury if other measures cannot be taken. These must comply with the requirements specified by the main contractor or operator of the operations room or the site in question.

If no requirements are specified, to operate the automat no PPE is required. Minimum requirements are well-fitting clothing and sturdy, closed and skidproof footwear.

Other services require the protective clothing and equipment necessary for the activity in question (e.g. transport and assembly: rugged, close-fitting work clothing, foot protectors [safety shoes with toe caps], head protection [safety helmet], hand protectors [protective gloves]; maintenance, repair and overhaul: rugged, close-fitting work clothing, foot protectors, hand protectors, eye/ face protector [safety goggles]).

4.12 Exceeding permitted pressure / temperature levels

Equipment used in combination with the expansion automat must guarantee that the permitted operating temperature and the permitted medium temperature (heat transfer medium) cannot be exceeded. Excess pressure and temperature may lead to component overload, irreparable damage to components, loss of function and, as a result, to severe personal injury and damage to property. Regular checks/inspections of these safeguards must be carried out. Service logs must be kept.

4.13 System water

Water which is non-flammable, does not contain solids or long-fibre components and does not present a danger to operations due to its contents, and will not affect or damage the water bearing components (e.g.: pressurised components, the diaphragm, vessel connection) of the expansion automat. Also observe: VDI 2035 - avoidance of damage to warm water heating equipment.

System water containing components are pipelines, hoses connected to the vessel, devices and system connections including valves and fittings, and their casings, sensors, pumps, the vessel itself and the vessel diaphragm. Operation with improper media can lead to impaired function, damage to components and, as a consequence, to serious personal injury and damage.

4.14 Safeguards

The equipment supplied is equipped with the required safety devices. To test their effectiveness or restore the set-up conditions, the equipment must first be taken out of service. Taking the system out of service implies that power should be cut and hydraulic connections blocked, to prevent accidental or unintentional re-connection.

Mechanical hazards:

The fan cover on the compressor protects users from personal injury caused by moving parts. Before switching the unit on, make sure that the cover is suitable for this purpose and properly secured.

Electrical hazards:

The protection class of electrically operated components prevents personal injury by electrocution, which can be fatal. The protection class is usually IP23. The control unit cover, the cover of the pump feed, the threaded cable glands and the valve connector plugs must be inspected for effectiveness prior to commissioning. The installed pressure and volume sensors are operated with protective extra-low voltage.

Avoid welding work on additional equipment which is electrically connected to the control unit. Stray welding current or an improper earth connection could lead to the danger of fire and damage to parts of the unit (e.g. the control unit).

4.15 External forces

Avoid any additional forces (e.g.: forces caused by heat expansion, flow oscillations or dead weights on the flow and return lines). These can lead to damage / leaks in water-bearing pipework, loss of stability of the appliance and furthermore to failure connected with substantial material damage and personal injury.

4.16 Inspection prior to commissioning, maintenance and re-inspection

They guarantee operational safety and its observance in line with applicable European regulations, European and harmonised standards and additional national regulations of the EU member states for this field of application. The required inspections must be arranged by the owner or operator; an inspection and maintenance log book for scheduling and traceability of measures taken must be kept.

Tests in line with the German ordinance on operational safety (BetrSichV, June 2015):

Pressure device, Vessel					
Category [Appendix II The Directive 2014/68/EC, Diagram 2]	Vessel Nominal Volume (l.)	Inspection prior to commissioning [§14] Inspector	Routine Inspection [§15 (5)]		
			Timeframe, maximum period [a] / inspector		
			External	Internal*	Strength*
III	400 / 6 bar 5000-10000/ 3 bar	Qualified Person (QP)	Not applicable [§15 (6)]	5 / QP	10 / QP
IV	600-3500/ 6 and 10 bar	Qualified Person (QP)	Not applicable [§15 (6)]	5 / QP	10 / QP

* [§15 (10)] In the case of internal inspections the visual inspection may be replaced by similar procedures and in the case of strength tests the static pressure test may be replaced by similar, non-destructive procedures if said tests would not otherwise be possible due to system design or not significant due to the system mode of operation.

In other Member States of the EC, the required tests for the pressure equipment in line with directive 2014/68/EU as defined in the national rules must be performed.

4.17 Electrical equipment inspections, routine inspection

Without prejudice to the considerations of the insurer/Operator, it is recommended that the electrical equipment of the Flamcomat be inspected and documented together with the heating/cooling unit no less than every 18 months (see also DIN EN 60204-1 2007).

4.18 Maintenance and repairs

These services may only be carried out when the system is shut down or if the expansion automat is not required. The pressurisation equipment must be taken out of service and guarded against unintentional re-starting until the maintenance work is finished. Note that the safety circuits and data transmissions made whilst shutting down could trigger the safety chain or lead to false information. Existing instructions for the heating or cooling unit as a whole must be observed. To stop hydraulic components, block the relevant sections and drain them using the safe system water drains through the available drain connections, and relieve the pressure.



Caution: The maximum system water temperature in conducting components (vessel, casings, hoses, pipelines, peripheral equipment) may reach 70 °C and, in the case of improper operation, may exceed that. This presents a danger of burns and/or scalding.



The maximum pressure of system water in conducting components may be equal to the maximum set pressure for the applicable safety valve.

Safety valve max. 6 or 10 bar. Use of eye/face protectors is required if the eyes or face could be injured by flying parts or spraying fluids.

To stop electrical equipment (control unit, pumps, valves, peripheral equipment), cut power to the control unit. The power supply must remain off for the period of the work.

It is forbidden to alter or use non-original components or replacement parts without authorisation. Such acts may result in serious personal injury and endanger operational safety. They will also render any claim for damages against product liability void. It is recommended to contact Flamco Customer Service for carrying out these services.

4.19 Obvious misuse

- Operation at incorrect voltage and/or frequency.
- Use in inappropriate system designs.
- Use of unpermitted installation materials.

4.20 Other hazards

- Overload of construction parts by the presence of unpredictable extreme values.
- Operational continuity at risk in the case of changed, non-permissible ambient conditions.
- Operational continuity at risk in the case of safety-control parts being taken out of service or malfunctioning.

5. Product description

The contents of this manual consist of the specifications for a standard execution. Where appropriate, this includes information on options or other configurations. If optional extras are supplied, further documentation will be supplied in addition to this manual.

For installation instructions and further documentation in various languages, visit www.flamcogroup.com/manuals. Further product information can be obtained from the respective Flamco branch office (see “Contact” on page 33).

5.1 Operating principle MK compressor automat

The varying pressure levels due to temperature changes in heating or cooling systems are continuously monitored by the pressure sensor in the compressed air compartment of the vessel. Comparison of these actual pressure levels with a programmable nominal value leads to the triggering of the valve (release of pressure by means of compressed air discharge) in the event of the value being exceeded (temperature rise), and triggering of the compressor (increase of pressure by means of filling the compressed air compartment with compressed air) in the event of the pressure dropping below the nominal level (temperature drop). The volume of water drained or fed in is made available or taken up by the vessel. Continuous comparison of the programmable nominal values with the varying volumes registered by the vessel volume sensor prevents under- or over-filling, whilst allowing volume increase by triggering external top-up devices.

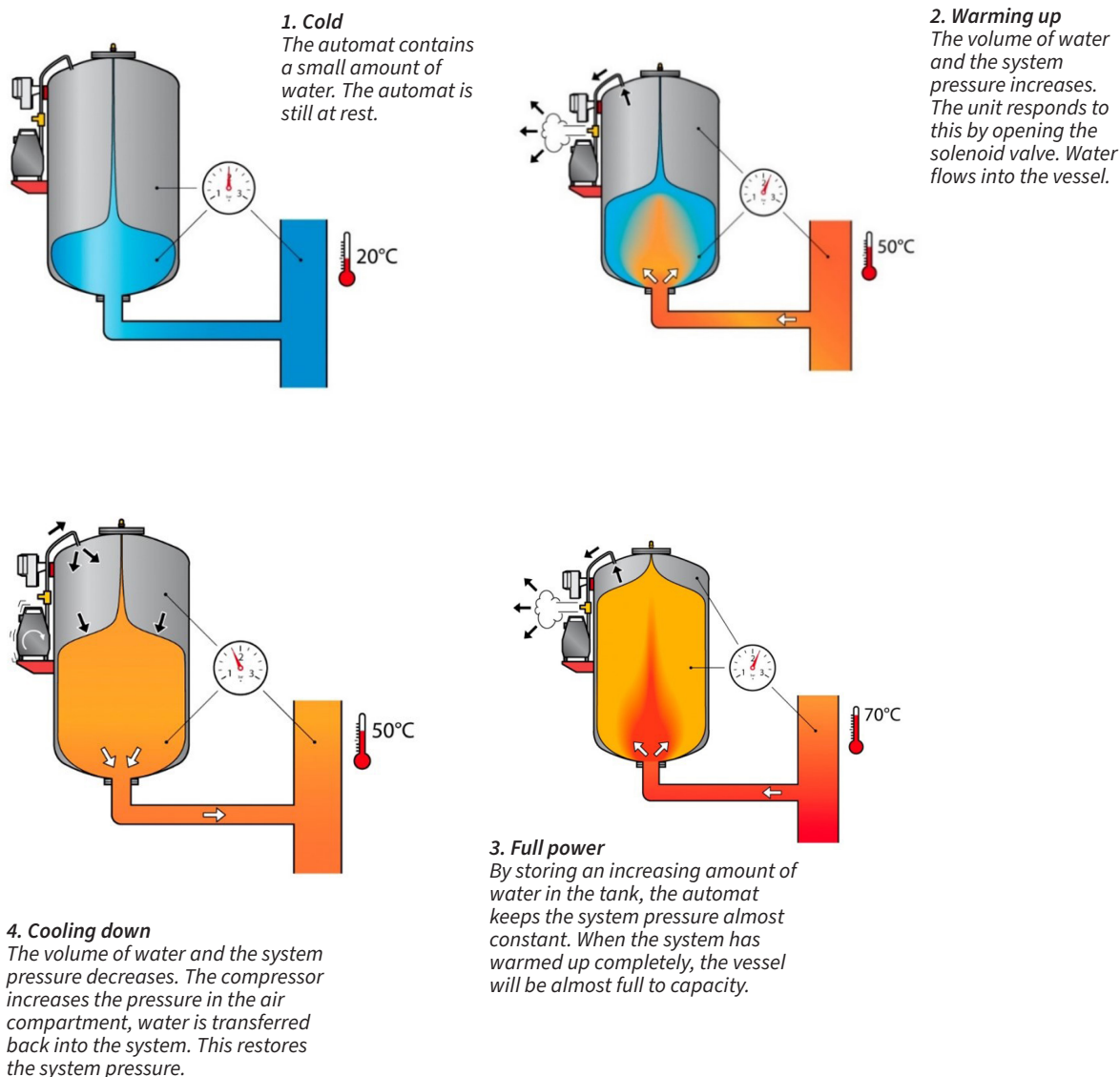

5.2 Connectivity options

Connectivity options	Designated use
Ethernet port	To connect Flamcomat to a Building Management System (BMS) via modbus or bacnet.
Standard USB (aka USB-A)	For saving the offline log and the configuration parameters. The second option for this port is to update the firmware of the controller (to download a new control SW)
CAN	This pair of the ports is dedicated for the networking of multiple Flamcomats
RS-485	The primary designation is to connect Flamcomat to Internet (via Gateway and HFC protocol). Alternatively - BMS via Modbus Alternatively - BMS via bacnet (only one out of three options at the same time)
Wireless	To connect a smartphone application

5.3 Markings

Name plate - Compressor module:

	Typ : Type : Type :	Serien-Nr. : Serial-No. : N° de Série : Volgnummer :	Schutzart : Protection cl. : Cl. de protection : Beschermingsgr. :
Flamco B.V. - Fort Blauwkapel 1 - 1358 DB LJ Almere - the Netherlands			
Nennspannung : Nominal voltage : Tension nominale : Nominale spanning :		Zulässige Medientemperatur min. / max. : Permissible media temperature min. / max. : Température de média mini. / max. admissible : Toegesane temperatuur media :	°C
Nennstrom : Nominal current : Courant nominal : Nominale stroom :	A	Zulässiger Betriebsüberdruck : Permissible working overpressure : Supression de service admissible : Toelastbare werkdruk :	bar
		Herstellungsjahr : Year of manufacture : Année de fabrication : Jaar van vervaardiging :	
Nennleistung : Nominal power : Puissance assignée : Nominaal vermogen :	kW	Zulässige Umgebungstemperatur min. / max. : Permissible ambient temperature min. / max. : Température de ambiante mini. / max. admissible : Toelastbare omgevingstemperatuur min. / max. :	°C

Transport lock:

Nach Montage:
Transportsicherung
entfernen.

After mounting:
Remove the transport
safety.

Après l'installation:
Retirez la sécurité des
transports.

Na montage:
Verwijder de veiligheid
van het vervoer.

Electrical warnings:

Attention, high voltage! Opening by qualified personnel only.
Disconnect the unit from the power supply before opening it.

Achtung, gefährliche Spannung! Nur vom Fachpersonal zu öffnen.
Vor dem Öffnen des Gerätes spannungsfrei schalten.

Service:

Service Nederland
Tel.: +31(0)36 52 62 530

Service Germany
Tel.: +49(0)170 630 40 34

5.4 Type key compressor control unit

Remark: keying is hardware specific, software is article number specific

E.g.: MK-C – 1 -50

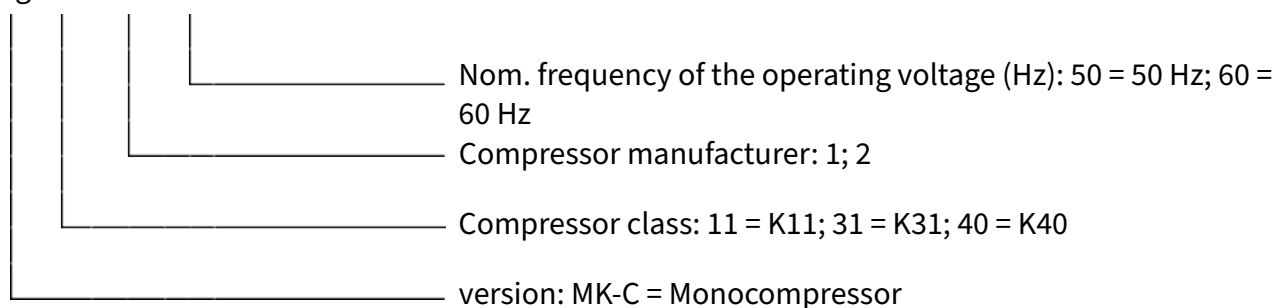

5.5 Component parts, vessels and connection assembly

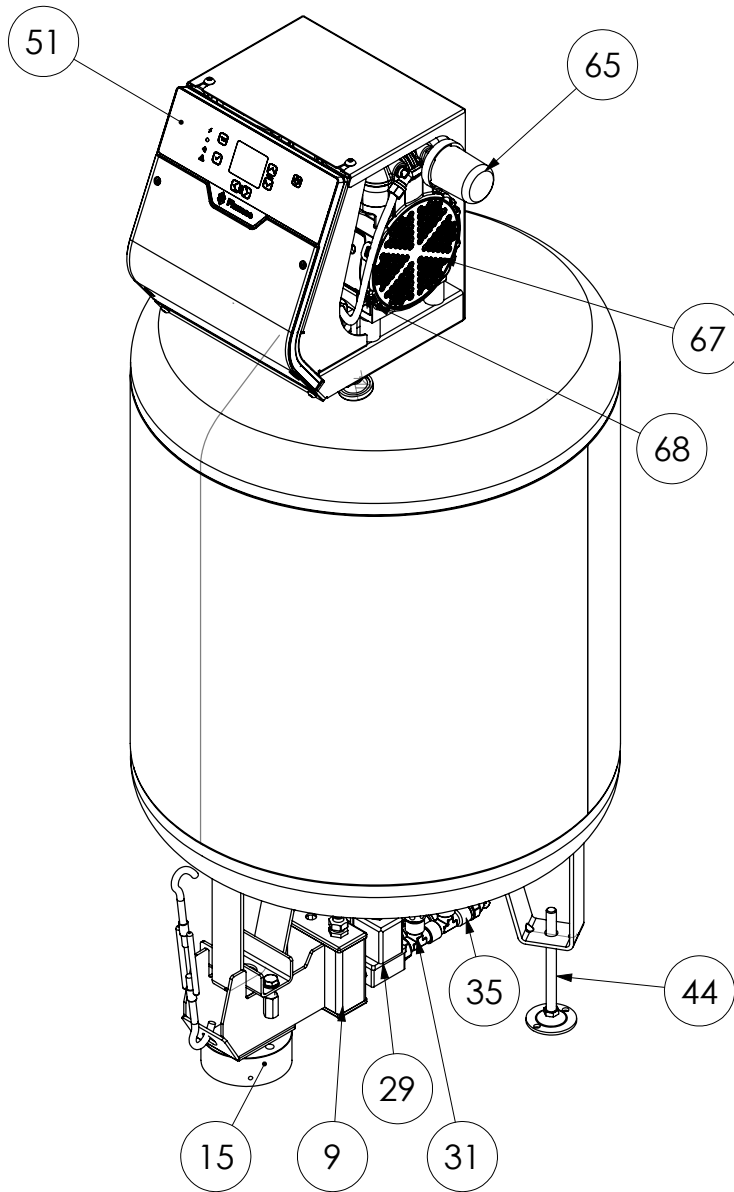

Nr.	Function
1	System connection hose
2	Vessel with fixed membrane
51	Flextronic controller
65	Air filter
67	Oil Free Air Compressor
68	Compressor valve
15	Level sensor
9	Membrane rupture sensor
29	Pressure release valve
31	Safety valve to compressed air compartment
35	Pressure sensor
44	Adjustment feet

5.6 Control unit

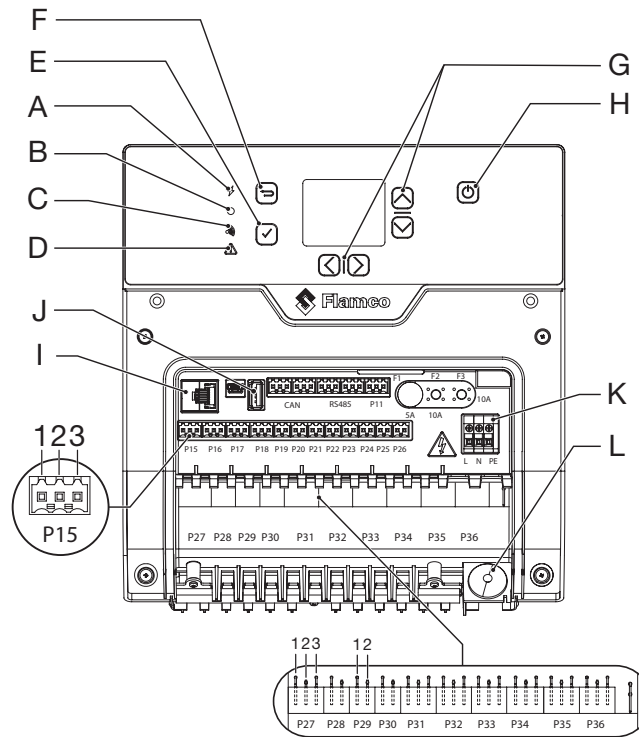

Identification	Description	Pinout
A	Power indicator (orange=power)	
B	Status indicator (green=ok automat running)	
C	Bluetooth indicator (blue light = active)	
D	Error/alarm (red=alarm/error active)	
E	Confirm button	
F	Return button	
G	Navigation buttons	
H	Screen on/of (hold 8 sec for powerdown)	
I	Rj45 connector used for Modbus/Bacnet over tcpip	
J	USB-A software update + logging	
CAN	CAN connection	1. CAN Hi 2. CAN Lo 3. GND
RS485	Modbus/Bacnet/HFC over RS485	1. B+ 2. B- 3. GND
F1	Fuse 1 (P31&P32) 5x20 5A	
F2	Fuse 2 (P33&P35) 5x20 10AT	
F3	Fuse 2 (P34&P36) 5x20 10AT	
K	Mains power connector	1. L 2. N 3. PE
L	Mains grommet	

P11	SELV, Vessel level Analog Out 0-10v	1. 0-10V 2. 4-20mA 3. GND
P15	SELV, Vessel level Analog Out 0-10v	1. +VDC 2. signal 3. GND
P16	SELV, Level 4-200mA	1. +VDC 2. -VDC 3. GND
P17	Not used	
P18	Not used	
P19	Not used	
P20	Not used	
P21	Not used	
P22	Not used	
P23	SELV, Diaphrag rupture sensor	1. NO 2. GND
P24	Not used	
P26	SELV, Pressure analog out	1. NO 2. GND
P27	Fault contact, Pot Free 1	1. NO 2. COM 3. NC
P28	Fault contact, Programmable fault output Pot Free 2 or Quickfill valve activation	1. NC 2. GND
P29	Fault contact, Programmable fault output Pot Free 3 or boiler interlock for 110deg kit	1. NC 2. GND
P30	Not used	
P31	Power, V3 Refill	
P32	Power, V4 Pressure release valve	1. PE 2. L 3. N
P33	Power, V1 Compressor valve 1	1. PE 2. L 3. N
P34	Not used	
P35	Power, M1 Compressor 1	1. PE 2. L 3. N
P36	Not used	

6. Assembly

6.1 Setup

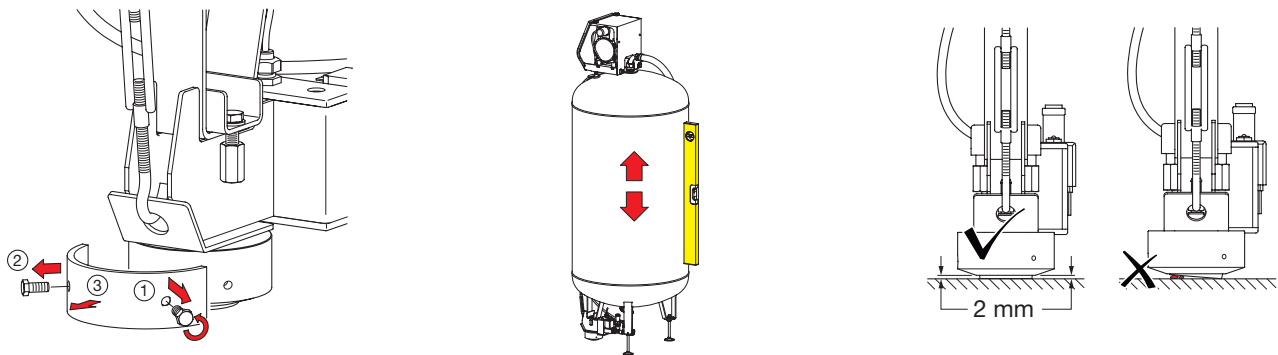

- Remove the transport seal by the capacity sensor once the basic vessel has been erected in the proposed place and no further positional changes are necessary. Try not to strike this sensor and make sure the sensor is on a surface which does not impair the function of the sensor pressure-pad.
- Using the foot-height adjuster, adjust the vessel until it is vertical. Use a magnetic spirit level.
- Ensure that no external forces can be exerted on the basic vessel (e.g. tools laid on the vessel, things leaning on the sides).
- Do not fix the basic vessel to the ground on which it is erected (do not use any sort of fastening which can adversely affect the vessel, e.g. sinking the feet into concrete or lime, welding on the vessel or its feet, clamps and ties on the body of the structure or appurtenances).

6.2 Vessel connection

The system connection should be connected to the heating or cooling system. Appendix 3 shows the installation diagram and an example installation.



Caution: Close ball valve and shut off system before working on the compressor automat.

Please observe the following specifications before filling and commissioning the pressure-expansion automat:

- The connection should preferably be made in the return flow of the heating or cooling system.
- Please note that a temperature at the system connection $> 70\text{ }^{\circ}\text{C}$ would exceed the permissible bladder load and possibly lead to damage to components.
(Complete insulation of the expansion lines may increase the temperature load on the bladder).
- Ensure that the connection from the main vessel to the system is made only by using the flexible pressure hose that has been supplied with the vessel.
- Make sure that this connection is made solely with the heat/cool generator, and that there are no external hydraulic pressure influences present at the point of entrainment (e.g. hydraulic balancers, distributors).
- Use sealant and pipework relevant to the installation; however, please observe at least the maximum permitted volumetric flow, pressure and temperature values for the expansion line in question.
- Fit isolating equipment in the immediate vicinity of the vessel connection to the system that cannot be closed unintentionally and preferably includes a fill and drain valve for the water compartments of the vessel. If this equipment is missing, install this additionally.
- When several vessels are placed in a pressure maintenance system, an extra ball valve is required at the expansion line before the connection to the main return line. It is recommended to seal this valve to protect against unintentional closing.
- The nominal diameters of the expansion line (supply or return connection from one or more vessels to the main return line) are to be chosen depending on the installed equipment and the distance to the main return line.

Pay attention to these recommendations based on practical experience:

Single vessel automat	
Length of expansion line	DN of the expansion line, in relation to the vessel connection
> 5 m	Two sizes bigger as vessel connection
> 15 m or > 8 m with 3 pipe bends	Three sizes bigger as vessel connection
> 22 m or > 15m	To be determined from actual values
> 30 m	Avoid at all times!

Advice: install expansion lines as short as possible and as flow-efficient as possible

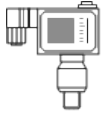

Systems with flow temperatures > 110 °C we recommend the Flamcomat kit 110 °C (17504)

	Legend	Optional	EN12953 required	Flamco recommended
A	Auxillary Vessel	X		
B	Main Vessel		X	X
C	Membrane rupture Sensor	X		X
D	Lockshield Valve with Draining	X	X	X
E	Auxillary vessel flexible Connection	X		
F	Flamcomat main Vessel flexible Connection		X	
G	Refill/ Top-up line (available with impuls water meter, water filter)	(x)		X
H	Refill / Top-up pump unit (for suppletion under system pressure)	X		(x)
I	Heat generator		X	X
J	Heating system supply line (>105 ° C)		X	X
K	Heating system return line (<90 ° C)		X	X
L	Intermediate Vessel Flexcon V-B	X	X	X
M	Minimum pressure Safety Switch	X	X	X
N	Bimetalic temperature Switch	X	X	X
O	Automatic controlled Compressor- / Pump Unit		X	X

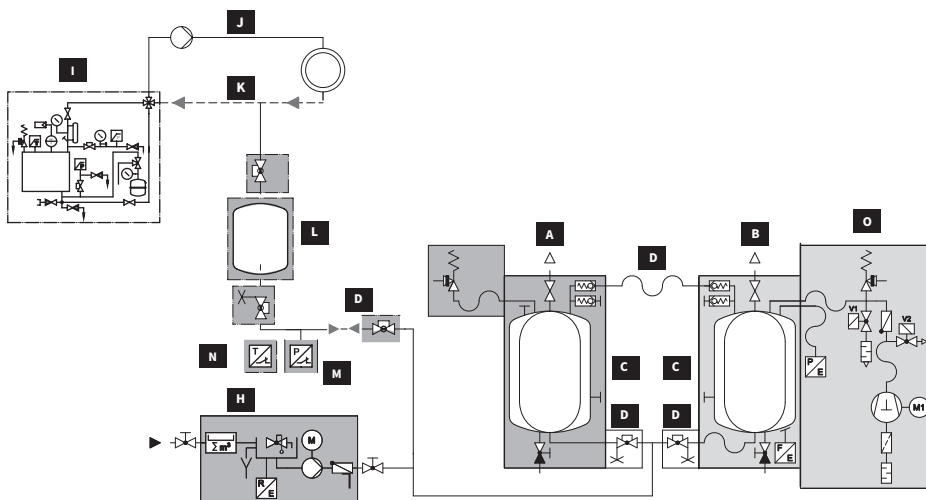

6.3 Electrical Installation

The provision of power supply, (protective) ground wire connection and line protection must be made in accordance with the regulations of the responsible power company and the applicable standards. The required information can be found on the type plate of the control unit, the terminal plan (labelling) and in “Appendix 3.” on page 33.

- All electrical connections should be carried out by a qualified and authorized electrician in accordance with the latest issue of the IET regulations. The equipment must be earthed. It is strongly recommended that a high-sensitivity differential switch (30mA) (residual current device RCD) is fitted on the incoming electrical supply.
- Do not remove covers without first ensuring that the electrical supply is suitably isolated and cannot be switched on.
- Do not attempt to supply electricity to the equipment unless the protective covers are correctly fitted and held securely in place.
- Cables connected to the controller volt free contacts may be supplied from another source and may remain live after the unit is isolated. These must be isolated elsewhere.
- The user or the installer is responsible for the installation of the correct earthing and protection according to valid national and local standards. All operations must be carried out by a qualified electrician.
- The Flamco equipment must be connected to a mains isolator switch with a contact gap of at least 3 mm
- It is recommended the switch should be installed within 2m of the equipment.



Hint: install equipotential bonding between earth connection and equipotential bonding conductor. The minimum diameter, quality and type of the power cables should apply to the on-site applicable rules and regulations for this application. The electrical control terminals must be connected at the set-up location to the mains power supply at the relevant operating voltage. The finished system allows the user to program the configuration and system-dependent parameters into the control unit.

7. Commissioning

7.1 Initial commissioning

- Document the commissioning procedure (actions and settings).
- Check that the installation and other actions prior to use have been carried out in full (e.g. power supply available and connected, functioning or active fuses, seal tightness of the equipment, transport protection of the volume sensor removed).

Commissioning is preferably done via Flamconnect App



Caution: Ensure that the basic vessel is not filled until all the commissioning measures have been completed.

- Connect the mains power, and accessory connections. Following the requirements in chapter 6.3 ‘Electrical installation’ and chapter 5.6 ‘The control plan’
- Check the operational readiness of the top-up line.
- Open the valve at the top-up connection and the lockshield valve at the flexible connection assembly (vessel connection).
- SWITCH ON THE CONTROL UNIT and run the Commissioning procedure (“7.4 Clarification of menu icons, function and location” on page 23, Commissioning).
- Follow the steps on the Flextronic controller to set up the MK Automat
 1. Language selection
 2. Time settings
 3. Activate Bluetooth
 4. Confirm manual is read
 5. Select vessel (only 1 possible selection)
 6. Level calibration (Vessel needs to be empty)
 7. Select accessories
 8. Confirm settings
- This start-up procedure is followed by switching ON the top-up unit (optional, see installation example with FlamcoFill P).
- In other cases the main vessel or all vessels are to be filled with a minimum water supply. The amount of water to be filled should be according to chapter 7.2. This value covers water losses and decreased filling levels caused by deaeration during operation. (Note the pressure difference between the available compressed air pressure and the flow pressure of the filling equipment! Also see instructions for re-filling).
- Open the ball valve on the cold-leg entrainment (system connection)
- Seal the lockshield valves.
- The completion of all the tasks to be carried out, the review of technical data, recommendations and explanations in this manual lead to the pressure expansion automat being ready for operation.

7.2 Commissioning, volume level and operating temperature

Advice: If a different volume level is required than the self-established minimum level after start (operational ready and installed top-up), the vessel should be filled according to the minimum required level needed for the actual system temperature, after completing the commissioning procedure on the control unit. For better understanding study the diagram below and the chapter on maintenance, vessel draining and re-filling later in this document.

Filling example I:

Maximum design temperature: 50 °C
 Maximum filling level: 92%
 Water trap (minimum water supply), re-feed level: 12%
 Minimum design temperature: 10 °C
 Actual temperature: 44 °C
 Read out fill level = 74%

Filling example II:

Maximum design temperature: 80 °C
 Maximum filling level: 92%
 Water trap (minimum water supply), re-feed level: 12%
 Minimum design temperature: 10 °C
 Actual temperature: 44 °C
 Read out fill level = 37%

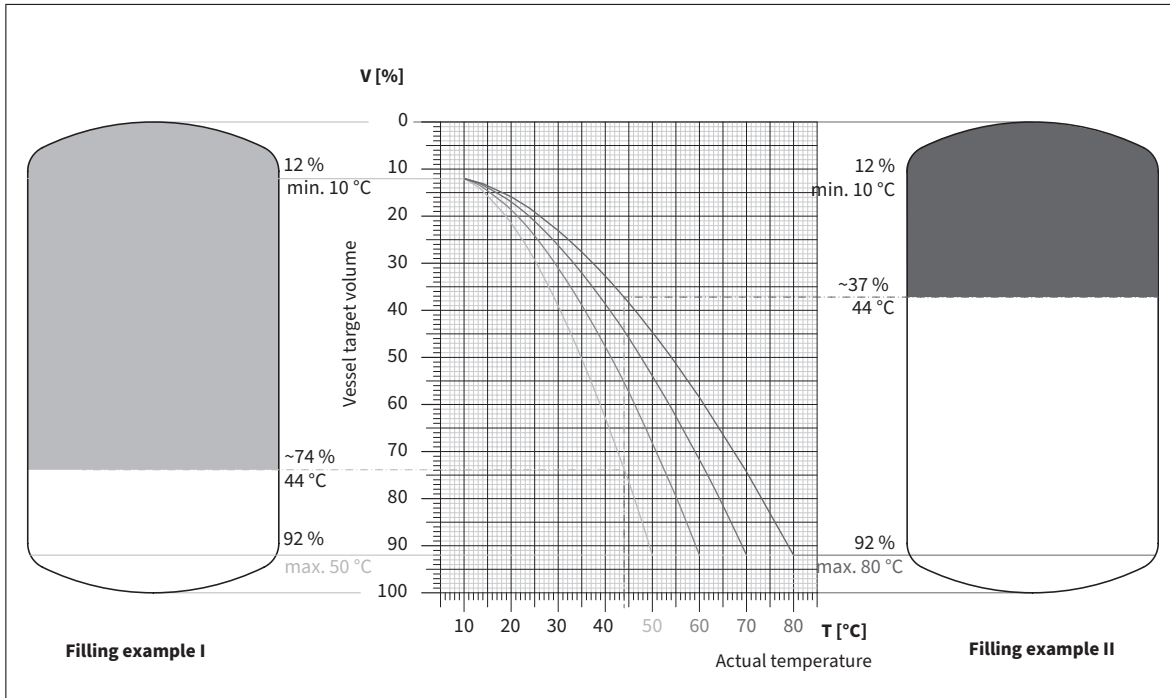

Filling example III:

Maximum design temperature: 25 °C
 Maximum filling level: 92%
 Water trap (minimum water supply), re-feed level: 12%
 Minimum design temperature: 6 °C
 Actual temperature: 22 °C
 Read out fill level = 73%





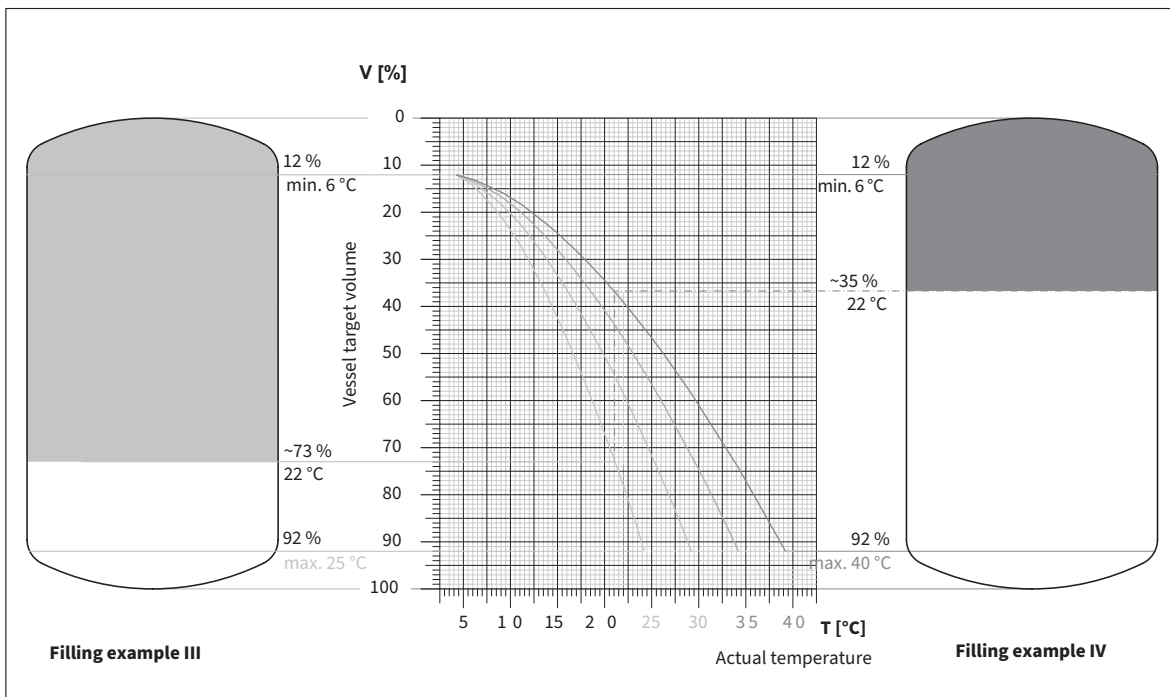



Filling example IV:

Maximum design temperature: 40 °C
 Maximum filling level: 92%
 Water trap (minimum water supply), re-feed level: 12%
 Minimum design temperature: 6 °C
 Actual temperature: 22 °C
 Read out fill level = 35%













7.3 Overview menu

options Download Flamconnect

Icon	Name	Function
	Language selection	To select the language of the interface
	Time-Date setting	To set the time and the date
	Connect via App	To pair your smartphone/tablet via wireless to proceed the commissioning with mobile
	I have read the manual	To confirm your awareness of the commissioning process
	Vessel type selection- vessel calibration	To select the (primary) vessel
	Pressure setting	To set the desired pressure setpoint
	Accessories selection	To select the additional control function of the automat
	Commissioning summary	To confirm the automat settings

7.4 Clarification of menu icons, function and location

Icon	Name	Function	Location
	Home	To observe the status of the automat	
	Settings	To launch the settings menu	
	Login	To login to access the advanced settings	
	Manual mode	To run a manual activation of the actuators	
	Service info	To observe the service information	
	Pressure	To change the operating pressure and the pressure tolerance interval	

Icon	Name	Function	Location
	Refill Level	To view the refill, drain and alarm levels	 
	General	To launch the general settings menu	 
	Alarms	To assign the alarm message(s) to the potential free output(s)	  
	Accessoires	To activate the advanced control accessories	  
	Time Date	To set the time and the date	  
	Language	To change the language of the interface	  
	Factory reset*	To reset the automat	  
	Firmware update*	To update the firmware	  
	Date	To set the date	   
	Time	To set the time	   
	System Info	To observe the automat and the controller information	 
	Error logbook	To read the last 30 error messages	 
	Maintenance	To see the next maintenance due date	 
	Operating Hours	To see the performance statistics	 
	USB detected	To save the log file to a USB stick	

* Only available when logged in

Operation screen

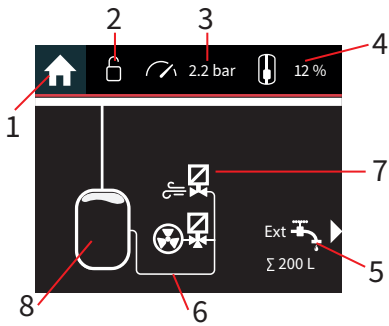

1. Screen icon
2. Advanced settings unlocked(login)
3. Current System Pressure
4. Current vessel level
5. Refill
6. System diagram
7. Pressure Release Valve
8. Compressor Vessel

Menu Screen

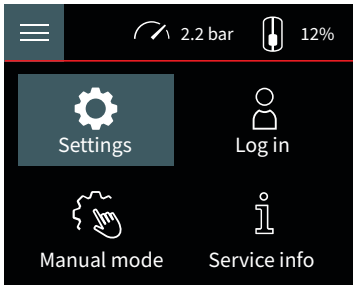

Settings screens



(login)
↓
Unlock advanced settings

Maintenance (Read-only) screen

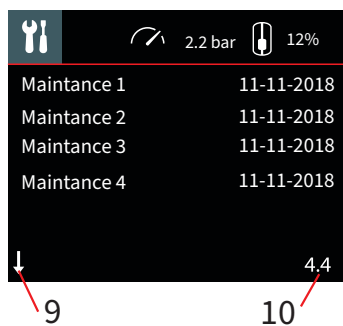

9. Scroll icon
10. Node number

7.5 Malfunction messages

Procedures and values for error identification, evaluation and output have been tried in practice, prevent secondary failures and invite user awareness. Please note that incorrect set-up conditions can lead to repeated errors and inhibit the intended use. Examples of incorrect set-up conditions are: incorrect or no longer applicable design, outdated equipment, incorrect installation and inadmissible operational parameters

Error #	GUI	Action
0	Single compressor maximum run time error	Compressor failure. Check functioning of compressor. Call Technical support if no solution can be found.
2	Load dependant compressors maximum run time error	Compressor failure. Check functioning of compressor. Call Technical support if no solution can be found.
3	Single compressor current error	Potential failure of compressor. Check electrical connection of compressor. Call Technical support if no solution can be found.
4	Compressor A current error (double compressor configuration)	Potential failure of compressor. Check electrical connection of compressor. Call Technical support if no solution can be found.
8	Self-learning valve correction error	Please reset the error by acknowledging the error in current error/warnings
9	Self-learning compressor correction error	Please reset the error by acknowledging the error in current error/warnings
10	Pressure sensor current exceeded	Check if the cable to the pressure sensor is not damaged
11	Pressure sensor no current	Check if the cable to the pressure sensor is connected
12	Load cell current exceeded	Check if the cable to the level sensor is not damaged
13	Load cell no current	Check if the cable to the level sensor is connected
14	Compressor power consumption too high	Potential failure of compressor. Check electrical connection of compressor. Call Technical support if no solution can be found.
17	Maximum run time M1 exceeded	The compressor runs too long. Please make sure there is no leakage in the system
20	Compressor running, no decrease of water level in vessel	Potential failure of compressor(s) or clogged tube
21	Valve open, no increase of water level in vessel	Potential failure of valve(s) or clogged tube
26	System run in auto mode	You have left the manual mode. Automat maintains the pressure
29	Manual mode active, press V to start automat	Acknowledge this message to run the automat in the AUTO mode (to leave the MANUAL mode)
30	Diaphragm rupture	The membrane is ruptured and should be replaced
32	Water level increase in vessel without Flexcon activity	Potential failure of manifold-, refill- or check valve
33	Water level decrease in vessel without Flexcon activity	Potential leakage of vessel or connection sets
34	Maintenance 1 is due	Carry out maintenance 1 (equipment service, every year)
35	Initial fill failed	Potential failure of refill valve or clogged supply tube
36	Maximum refill time exceeded	Potential failure of refill valve
38	No refill flow	Please make sure the litre counter is available
39	Amount refill water too much	System requires to much refill. Potential leakage
43	Initial fill active	The automat fills a vessel with minimum amount of water
44	Manual initial fill active	Fill in a vessel with minimum amount of water
47	Maintenance 2 is due	Carry out maintenance 2 (inspect vessel internally, every 5 years)
48	Maintenance 3 is due	Carry out maintenance 3 (strength inspection to vessel, every 10 years)
49	Maintenance 4 is due	Carry out maintenance 4 (inspect electrical equipment, every 1,5 years)
64	Low pressure alarm	System pressure is lower than "Low Pressure Alarm"
65	Higher pressure exceeded	System pressure is higher than "High Pressure Alarm"

66	Water Level below minimum value	Water level in a vessel is lower than “Low level limit”
73	Time between refill processes too short	System requires to much refill. Potential leakage
74	Number of refills within certain time exceeded	System requires to much refill. Potential leakage

7.6 Restarting

After long periods of downtime:

- If this downtime was planned or scheduled, turn OFF the control unit and close off the lockshield valves to the system and the isolating valve to the top-up line. After that decompress and then drain the water area. We recommend you carry out maintenance before restarting (see chapter 8 Maintenance).
- Use the commissioning records for restarting and check especially for system changes that can lead to other operating conditions of the expansion automat (e.g. system pressure).

If the power supply has failed:

- The target parameters and default settings for pressure, aeration and top-up will remain unchanged, meaning automatic operation will resume automatically when power is restored (control unit ON). Extraordinary system operating conditions (e.g. cooling to below the default setting) may fall outside the permitted settings of the expansion vessel.

Caution: please ensure that when the system cools down or warms up, the minimum or maximum system pressure does not exceed or fall below the permitted operating pressure. Under- and over-pressure safety for operation of heating or cooling systems are not within the standard scope of supply of the Flamcomat MK.

Check the automat’s operation once power supply has been restored and, if necessary, set the actual date and time values (overview menu options).

8. Maintenance

8.1 Maintenance Warnings

Electrical supply must be disconnected prior to conducting any maintenance. To supplement, or in addition to, the stipulations made in the overall project, perform the following:

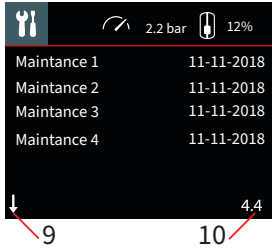

Maintenance due date is shown in menu 4.4.



Maintenance warnings pops-up when date is due. Warning gets stored in the Current errors/warnings list and Error logbook.

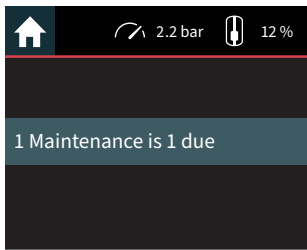

Acknowledging the “maintenance 1 is due” Warning in the Current errors/warnings list is equal to resetting the maintenance 1 due date.

8.2 Maintenance schedule

		Objects, standard scope of supply	Service activities, measures
Monthly inspection (No Warning Message)	30 days	Compressor, oil-free [25-28]*	Inspect and/or clean filter element [65]* & Air inlet when dirty (dry installation required)
		Main vessel	Drain condensate; Deaerate water compartment*(NA. for vessels with air-vent [31]*)
		Clean particle filter	Clean filter element [65]* & Air inlet* when needed (dry installation required)
Maintenance 1	365 Days	Compressor [67], Pressure release valve[29], Compressor valve 1[68]	Function check. To be carried out manually by trained and certified personnel. Other inspections can be done during operation of the device.
		Control unit [51]*, configuration	Inspect and restore the required settings (overview menu)
		Main vessel, auxiliary vessel MK, Compressor module [67]* & connection assembly.	Check for leaks at all the connections to the vessel at both compressed air- and water compartments (visually). Check externally for damage, deformation or corrosion and restore operational readiness.
		Safety valve[31]*	Function check. To be carried out manually by trained and certified personnel. (DO NOT PRESSURIZE VESSEL TO SAFETY VALVE LIMITS)
		Main vessel, auxiliary vessel MK	Inspect vessel internally! Consider recurring inspections, see general safety instructions!
Maintenance 2	1825 Days		Carry out strength inspection to vessel!
Maintenance 3	3650 Days		Carry out recurring inspection of electrical equipment!
Maintenance 4	584 Days		Electrical inspection

* See “Chapter 5.5 Component parts” on page 15.

8.3 Vessel draining/refilling.

If draining of expansion water in the vessel is necessary, please consider the following order of actions:

- Record the actual volume level (%) as shown on FLEXTRONIC control unit display.
- Switch the control unit OFF (hold O/I button for 8 seconds).
- Close the lockshield valves on the expansion pipe (system inlet and outlet) and on the connecting array (vessel inlet and outlet)
- If a refill connection is installed. Close the isolating valve at the top-up connection.
- Carry out the required work on the vessel (drain, service, repair etc.).
- Switch the control unit ON; Login, go to factory reset* and run Commissioning procedure (overview menu options; Commissioning 1-1.8)
- If a refill connection is installed. The initial procedure is started automatically after commissioning.
- Note: when a refill bigger than the default setting for minimum vessel filling volume is required (6%), open the lockshield valve on the vessel connection. Make sure that the volume level detection is made by using the volume sensor of the main vessel.
- Disconnect the filling equipment.
- The operational mode has been restored.
- There are 2 questions in this menu item. Only when these are confirmed, the reset takes place.



Caution: At the moment of restarting the system some logical errors may arise that are self-acknowledging or acknowledged.

9. Decommissioning, dismantling

At the end of the service life or at planned shut-down of the equipment, please make sure that the module is separated from the power supply. The hydraulic system connections and top-up connections should be closed off.



Caution: water areas should first be made pressure less and empty when the destination or re-use of system water should be designated in conformity with the applicable rules. This water may be treated, contain anti-freeze or other additives.

The designation of further processing of the construction parts should be carried out in agreement with the required waste management service provider.

10. Flamconnect Remote

The Flamcomat MK-C G4 Remote comes with a 3-year Flamconnect Remote.

Flamconnect Remote provides the option to read and control the Flamcomat MK-C G4 Remote via the Flamconnect Remote Portal. More information can be found at <https://flamco.aalberts-hfc.com/nl/page/services/flamconnect-remote>.

A Gateway is used to make communication possible. This gateway connects to the Flamcomat MK-C G4 Remote via RS485. The gateway is connected to the Flamconnect Remote Portal via a GSM network.

After you have completed the registration of the gateway, you will have access to the Flamconnect Remote Portal.

Requirements for proper operation.

- There must be good GSM coverage where the gateway is located.
If this is not the case, item S90009 can be ordered. This is an antenna with cable, the cable can be connected to the gateway, the antenna can be placed at a location with a good GSM network.
- Check whether the antenna is properly connected to the gateway.
- Communication from the Flamcomat MK-C G4 Remote RS485 port must be set to “gateway”.
- The serial number required during registration can be found on the back of the gateway.

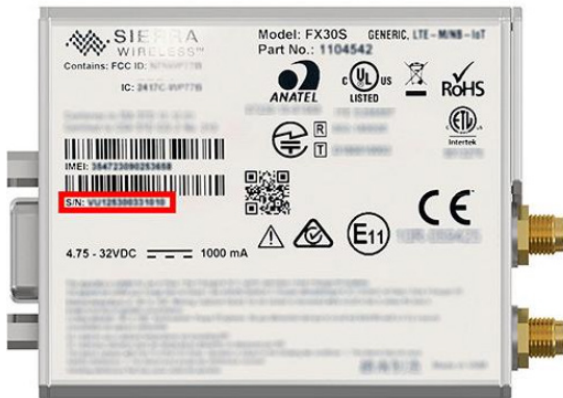

Security

What safety measures are there?

We take your data very seriously, so we have a host of security measures in place to ensure your data stays safe. Below is a small subset of these measures to give an idea of their scope:

- The portal team has a daily focus on security, with peer reviews, static code checking, automated testing, etc.
- Security is designed into the multi-level portal. Developers, for example, must explicitly code for situations where they need data that would normally not be accessible to the logged in user, because otherwise that data is simply «invisible.»
- All access is password protected. All users are authorized using roles and permissions using standard Microsoft certified solutions.
- IoT connections are encrypted with TLS and access keys or certificates (depending on customer requirements).
- Our portal has measures to actively protect against CORS, XSS, Content-type sniffing, Framing, etc.
- Actions on sensitive data (e.g. device data / user accounts) are logged in an audit trail.
- Deployments are fully automated to avoid configuration errors that could lead to security breaches.
- Internal and external security is actively screened through pen tests and security audits.
- In addition to our built-in security measures, we can also configure additional measures, for example Cloudflare to protect against DDOS attacks or Azure API Management to throttle API clients that make too many requests.
- Last but not least, we use Microsoft Azure and all it has to offer in terms of security, data encrypted at rest, keyvaults, no practical physical access and of course their team of world class security experts!

By using Flamconnect Remote you agree to the Contract and Terms of Use”.

Appendix 1. Technical data, information



Caution: DO NOT STACK!

Ambient conditions

Storage		
Room:	Protected against:	Ambient conditions:
Locked	Solar radiation	60 ... 70 % relative humidity, non-condensing
Frost-free	Thermal radiation	Maximum temperature 50 °C
Dry	Vibration	Free of electrically conductive gases, explosive gas mixtures, aggressive atmosphere

Operations room		
Room:	Protected against:	Ambient conditions:
Locked	Solar radiation	60 ... 70 % relative humidity, non-condensing; temperature 3 - 40 °C
frost-free,	thermal radiation	depending on type 3 - 50 °C;
dry	vibration.	free of electrically conductive gases, explosive gas mixtures, aggressive atmosphere. Caution: Higher temperatures may lead to overload of the compressors.

Minimum distances

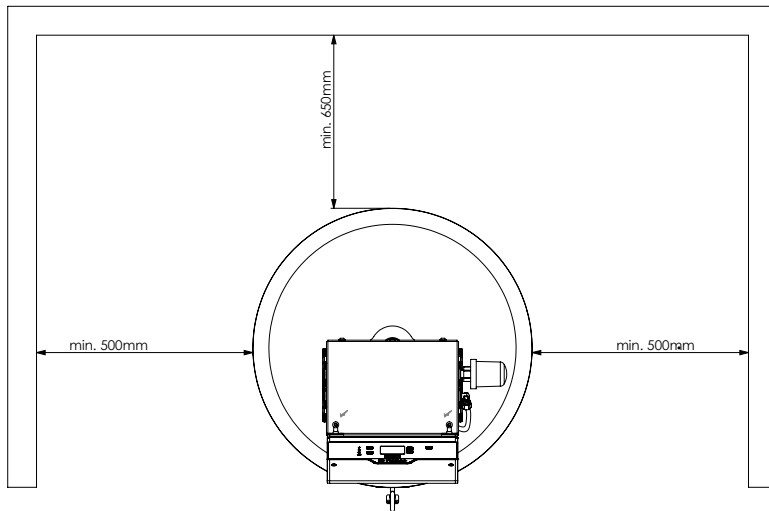

Installation examples
Distance system supply, system discharge, at return integration point, in the range 0.5 ... 1 ... m.

Please note: If the return line is routed horizontally, do not implement the connection from below to avoid additional contamination with dirt.

1. For design temperatures > 100 °C and > 110 °C, additional requirements from applicable European standards may apply.

Appendix 2. Technical data, specifications, hydraulic equipment
Operational values, volumes and dimensions

Name	PN rating	Nominal voltage	Nominal capacity	Nominal Current	Media Temperature	Ambient temperature	Protection class	Working pressure max (Bar)	System connection	A	B	C	Dry weight [Kg]
Flamcomat MK-C 110 G4	6 Bar	230 V - 50 Hz	0,37 kW	5,1 A	3 / 70 C	3 / 40 C	IP 23	5,4	G1	509	1225	300	38
Flamcomat MK-C 200 G4	6 Bar	230 V - 50 Hz	0,37 kW	5,1 A	3 / 70 C	3 / 40 C	IP 23	5,4	G1	600	1400	380	55
Flamcomat MK-C 325 G4	6 Bar	230 V - 50 Hz	0,37 kW	5,1 A	3 / 70 C	3 / 40 C	IP 23	5,4	G1	790	1620	610	77
Flamcomat MK-C 350 G4	6 Bar	230 V - 50 Hz	0,37 kW	5,1 A	3 / 70 C	3 / 40 C	IP 23	5,4	G1	600	1820	380	79
Flamcomat MK-C 425 G4	6 Bar	230 V - 50 Hz	0,37 kW	5,1 A	3 / 70 C	3 / 40 C	IP 23	5,4	G1	790	1465	610	71

Appendix 3. Technical data, information, electrical equipment

Compressor unit, nominal values

Type	Nominal voltage (V)	Nominal current (A)	Nominal capacity (kW)	Fuse line protection (on-site, recommended)
MK-C	230 V ~1 N PE 50 Hz	5.1	0.37	6 A (C)

* The rated current of the refill unit Flamcofill-P - 1.2A (0.3kW)

Control unit, terminal plans

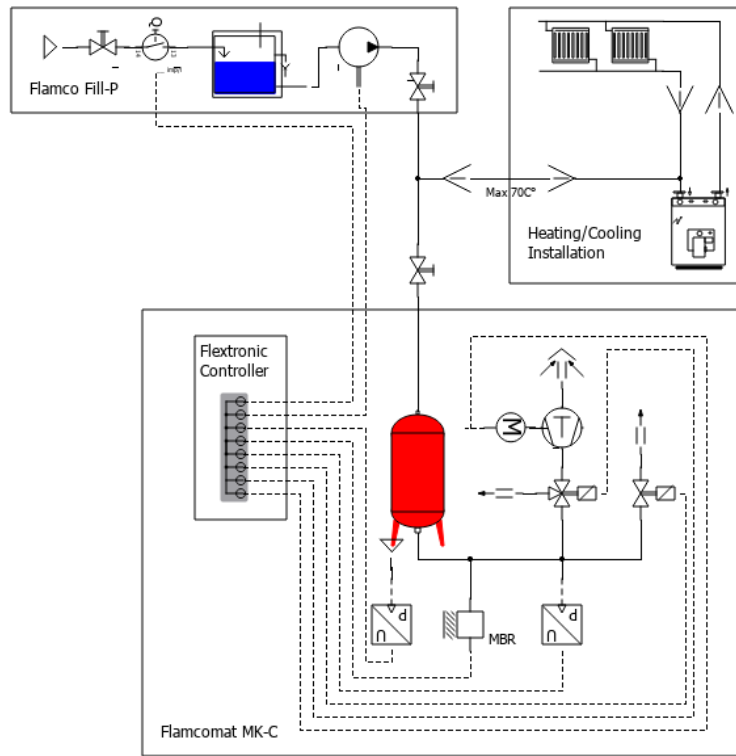

Contact

The Netherlands

hydronic flow control
+31 (0)36 52 62 300
info@flamcogroup.com
www.flamcogroup.com

Belgium

hydronic flow control
+32 2 371 01 67
info@flamco.be

Denmark

Flamco Denmark
+45 44 94 02 07
info@flamco.dk

France

hydronic flow control
+33 4 78 78 16 00
info@flamco.fr

Hungary

Flamco Kft
+36 23 880981
info@flamco.hu

Russian Federation

ООО „Майбес РУС“
+7 495 727 20 26
moscow@flamcogroup.ru

Switzerland

Flamco AG
+41 41 854 30 50
info@flamco.ch

China

Flamco Heating Accessories
(Changshu) Ltd, Co.
+86 512 528 417 31
yecho@flamco.com.cn

Estonia

Flamco Baltic
+372 568 838 38
info@flamco.ee

Germany

Meibes System-Technik GmbH
+49 342 927 130
info@meibes.com

Italy

Flamco Italy
+39 030 258 6005
flamco-italia@flamcogroup.com

Slovakia

Flamco SK s.r.o.
+421 475 634 043
info@meibes.sk

United Arab Emirates

Flamco Middle East
+971 4 8819540
info@flamco-gulf.com

Czech Republic

Flamco CZ s.r.o.
+420 284 00 10 81
info@meibes.cz

Finland

Flamco Finland
+358 10 320 99 90
info@flamco.fi

Germany

Flamco GmbH
+49 2104 80006 20
info@flamco.de

Poland

Flamco Meibes Sp. z o.o.
+48 65 529 49 89
info@flamco.pl

Sweden

Flamco Sverige
+46 50 042 89 95
vvs@flamco.se

United Kingdom

Flamco Limited
+44 17 447 447 44
info@flamco.co.uk

Flamco B.V.
Fort Blauwkapel 1
1358 DB Almere
the Netherlands
+31 (0)36 52 62 300
info@flamcogroup.com
www.flamcogroup.com

Man_Flamcomat_MK-C_G4_eng_2023-12

Copyright Flamco B.V., Almere, the Netherlands. No part of this publication may be reproduced or published in any way without explicit permission and mention of the source. The data listed are solely applicable to Flamco products. Flamco B.V. shall accept no liability whatsoever for incorrect use, application or interpretation of the technical information. Flamco B.V. reserves the right to make technical alterations.