

Technical information for installation and operation

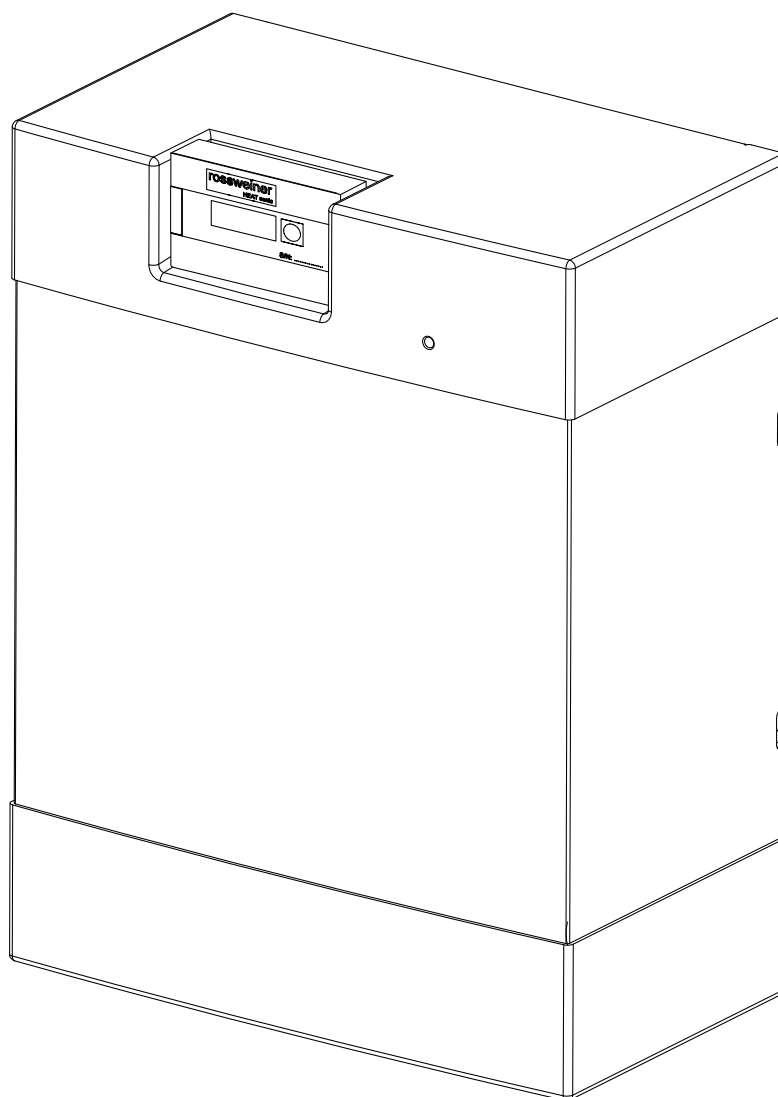

LogoEco Heat Interface Unit (HIU) A2RXE

Instantaneous Hot Water & Space Heating













GB

Contents

1.	Operation	4
1.1	Space heating (SH)	4
1.2	Domestic hot water (DHW)	4
1.3	Priority switching	4
2.	General Plumbing Requirements	5
2.1	British and Irish standards	5
2.2	Fitting and modifications	5
2.3	District heating	6
2.4	Space heating	6
2.5	Domestic water	7
2.6	Servicing	7
3.	General Wiring Requirements	8
3.1	Danger of short circuit	8
4.	Application	9
4.1	Status indicator LED	9
5.	Specification	10
5.1	Facts And Figures	11
6.	Installation	12
7.	Service	15
7.1	Filling the space heating system	15
7.2	Air venting the HIU	15
7.3	Room thermostat	17
7.4	Power supply	18
7.5	Commissioning	19
7.6	Removing and securing the case	20
7.7	Grundfos Pump	21
7.8	Performance view	21
7.9	Hot Water Circulation	22
7.10	Different pump modes	23
7.11	Heat Meter	24
7.12	Troubleshoot (technician)	25
8.	Appendix A	27
	Appendix B	31
	Appendix C	32

Symbols and abbreviations

Symbols

	CAUTION, general safety remark		Recycle component if possible
	CAUTION, risk of shock		Wrench, manual tool
	CAUTION, hot surfaces, risk of burns		Drill, power tool
	CAUTION, hot water, risk of burns		Manual operation, no tools needed
	Important note		Philips Screwdriver
	Requirement of 230 Volt Alternating Current		Insulated flathead screwdriver
	Dispose component		

Abbreviations

DH	District heating	A	Current in Ampere	kg	Weight in Kilograms
SH	Space Heating	N	230VAC Neutral	mm	Distance in millimetres
DHW	Domestic Hot Water	L	230VAC Live (phase)	PN	Pressure class in Bar
DCW	Domestic Cold Water	PE	Protective Earth	"	Thread size in inch (ISO 228/1)
VAC	Volts Alternating Current	°C	Temperature in degrees Celsius	HIU	Heat Interface Unit
VDC	Volts Direct Current	kPa	Pressure KiloPascal	ABV	Automatic Bypass Valve

1. Operation

1.1 Space heating (SH)

The heat exchanger physically separates the district heating network from the space heating circuit. The application minimizes the risk of contamination of district heating water as well as the risk and consequences of leakage in the space heating circuit. The electronic regulator in the unit, together with electronic control valves and temperature sensors regulates the temperature of the space heating.



CAUTION!

Caution
Hot
surface

Components, pipes and radiators in, and connected to, the unit may be hot. The heat interface unit is designed for use with space heating systems up to 90°C. The pipes and components in the unit as well as the pipes and radiators in the space heating installation can reach these temperatures. Contact may lead to burns.

1.2 Domestic hot water (DHW)

The HIU is equipped with single wall plate heat exchangers. The heat exchanger transfers the heat from the heat distribution system to the domestic hot water. The electronic controller in the unit, together with electronic control valves, temperature sensors and flow sensor regulates the temperature of the hot water to its set point (default 55°C).

The unit has two DHW keep hot modes – Eco or Comfort mode. The default setting is Eco mode and in this mode the heat exchanger is kept up to temperature for 1 hour after the last hot water draw off. After 1 hour of inactivity the temperature is allowed to drop to minimize energy consumption. The comfort mode setting is optional and can be selected at the point of commissioning. In this mode the heat exchanger is continuously kept warm for quicker hot water delivery. To prevent legionella from growing, the heat exchanger is heated to 55°C every 24 hours for at least 30 minutes. When the unit is fitted with the optional DHW circulation pump, the unit must be set to comfort mode.



CAUTION! Hot water

Caution
Hot water

The hot water temperature is regulated to 55°C (default value). If there is a power outage during tapping conditions the unit will stop regulating the domestic hot water temperature. This may lead to a domestic hot water temperature that is higher or lower than its set point. Hot water can cause burns.

1.3 Priority switching

The HIU is fitted with priority switching. When hot water is drawn off, the HIU diverts all the DH flow to heat up the domestic water. If there is a power outage during tapping conditions or during a situation where there is no request for heat from the (connected) thermostat, the space heating valve will stay in closed position. This may lead to a decrease in temperature of the space heating installation/circuit.

2. General Plumbing Requirements

When installing a completely new SH system in a new build property or a first time installation in an existing property, then the heating system must conform to current building regulations Part L1a.

The appliance must be installed in accordance with, and comply to, the current: IEE Regulations, Building Regulations, Building Standards (Scotland) (Consolidation), Building Regulations (Northern Ireland), local water by-laws, Health & Safety Document 635 (The Electricity at Work Regulations 1989) and any other local requirements.

2.1 British and Irish standards

Where no specific instruction is given, reference should be made to the relevant British and/or Irish Standard codes of Practice.

BS7074:1	Code of practice for domestic and hot water supply
EN12828	Space heating for domestic premises
BS7593	Treatment of water in domestic hot water space heating systems
ECTI	National rules for electrical installations

Keep following conditions in mind during installation:

- The HIU can only be used with closed heating systems up to a temperature of 90°C.
- The HIU must be stored and installed in a frost free area.
- The HIU must not be exposed to direct sunlight.
- Ambient temperature must be between +5°C and +40°C.
- Humidity must be between 20% and 80%.
- Temperatures of components in the HIU and connected to the HIU can reach high temperatures. Contact may lead to burns.

2.2 Fitting and modifications

Fitting the appliance and any controls to the appliance may only be carried out by a competent engineer. Any misuse or unauthorised modifications to the appliance or associated components and systems could invalidate the guarantee and may lead to serious injury or even death. The manufacturer accepts no liability arising from any such actions, excluding statutory rights.

2. General Plumbing Requirements

2.3 District heating



CAUTION!

Caution
Hot
surface

Components, pipes and radiators in, and connected to, the unit may be hot. The heat interface unit is designed for use with centralized heating systems up to 90°C. The pipes and components in the HIU as well as the pipes and radiators in the space heating installation can reach these temperatures. Contact may lead to burns.

Keep following conditions in mind during installation:

- Maximum pressure supplied by the district heating network is 16 bar.
- Maximum differential pressure supplied by the district heating network is 250 kPa. (450 kPa when Differential Pressure Control Valve (DPCV) is fitted)
- Maximum supplied temperature by the district heating network is 90°C.
- Minimal supply temperature is set-point DHW + 5°C.

2.4 Space heating (SH)

Before the HIU is commissioned, the SH circuit must be fitted with an automatic by-pass valve to maintain a minimal flow rate over the HIU. The valve must be installed between the SH supply and return, noting the direction of flow.

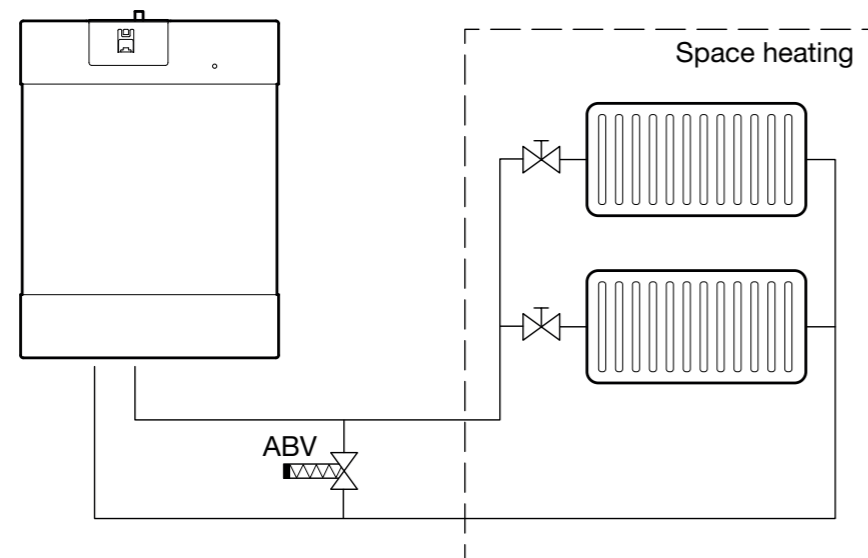

ⓘ For optimal energy efficiency and comfort, it is of the utmost important to hydraulically balance the SH circuit correctly. For the same purpose it is advised to design the SH circuit in such a way, that the SH return temperatures are as low as possible.

Keep following condition in mind during installation:

- Artificially softened water must not be used to fill the space heating system

2. General Plumbing Requirements

2.5 Domestic water (DHW)

The DHW circulation pump is an available option within the HIU. The circulation system, connected to the HIU, must not contain any closable valves or obstructions to ensure that a continuous flow will always be possible. Applying valves to the system can cause pump failure due to insufficient flow.

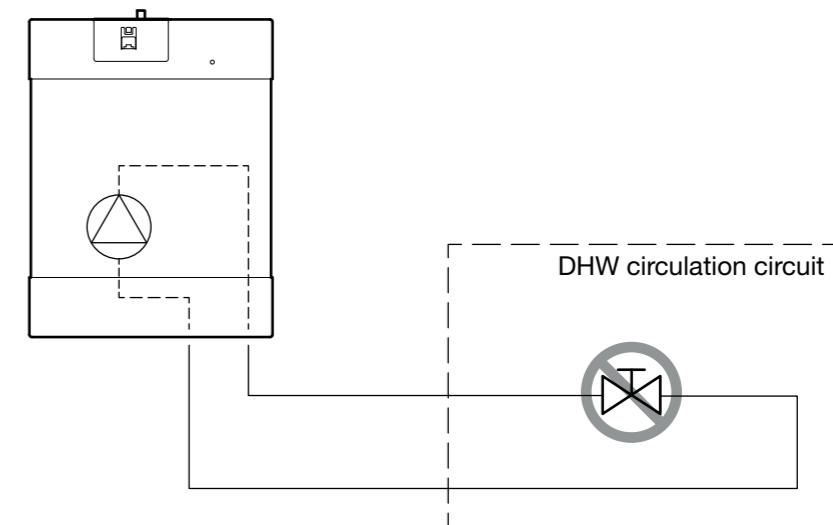

Keep following condition in mind during installation:

- Maximum pressure supplied by the domestic water circuit is 10 bar.
- All seals, joints and compounds (including flux and solder) and components used as part of the secondary domestic water system must be approved by WRAS.

2.6 Servicing

The end user should be advised to have the system serviced annually by a competent engineer. Contact your supplier for a list of approved engineers. Approved spares must be used to help maintain the economy, safety and reliability of the appliance. The service engineer must complete the Service Record after each service.

3. General Wiring Requirements

These instructions apply in the UK and Ireland only and must be followed except for any statutory obligations. Component specific electrical information may also be supplied in support of these instructions.

FAILURE TO INSTALL APPLIANCES CORRECTLY COULD LEAD TO PROSECUTION.



CAUTION!

Danger
Electric
shock risk

Isolate the mains supply before starting any work and observe all relevant safety precautions. The HIU uses electrical components (230VAC and 24VDC). These components must stay dry at all times. Touching these components can result in an electrical shock, burn, or electrocution.

When the HIU is permanently connected to the 230VAC installation, a switch or circuit-breaker must be included in the installation as the means for disconnection. The switch or circuit-breaker must be suitably located next to the appliance and easily reached. The switch or circuit-breaker must be marked as the disconnecting device for the equipment.



CAUTION!

Danger
Electric
shock risk

The HIU mains supply must always be connected to a residual current circuit breaker with overcurrent protection (RCBO) that combines the functionality of a RCD and MCB, breaking the circuit on either incorrect current or overcurrent. The circuit breaker must have a contact separation of at least 3mm in all poles and should isolate the appliance and all associated controls. The HIU must, at all times, be connected to the protective earth of the installation.

3.1 Danger of short circuit

When connecting the cables ensure that no cable pieces fall inside the control panel. Unless otherwise stated, all HIU's should be connected to a mains 230V 50Hz Supply fused at 3 Amps. All electrical connections with the HIU control panel are clearly marked as follows:

L = Live 230V

N = Neutral

E = Earth

PE = Protective Earth

Any additional mains cable should comply fully with the current I.E.E. wiring regulations. It must have a minimum section of 1.5mm² and be capable of withstanding a minimum of 90°C.

4. Application

The HIU A2RXE is used to provide domestic hot water and space heating in residences connected to a district heating system.

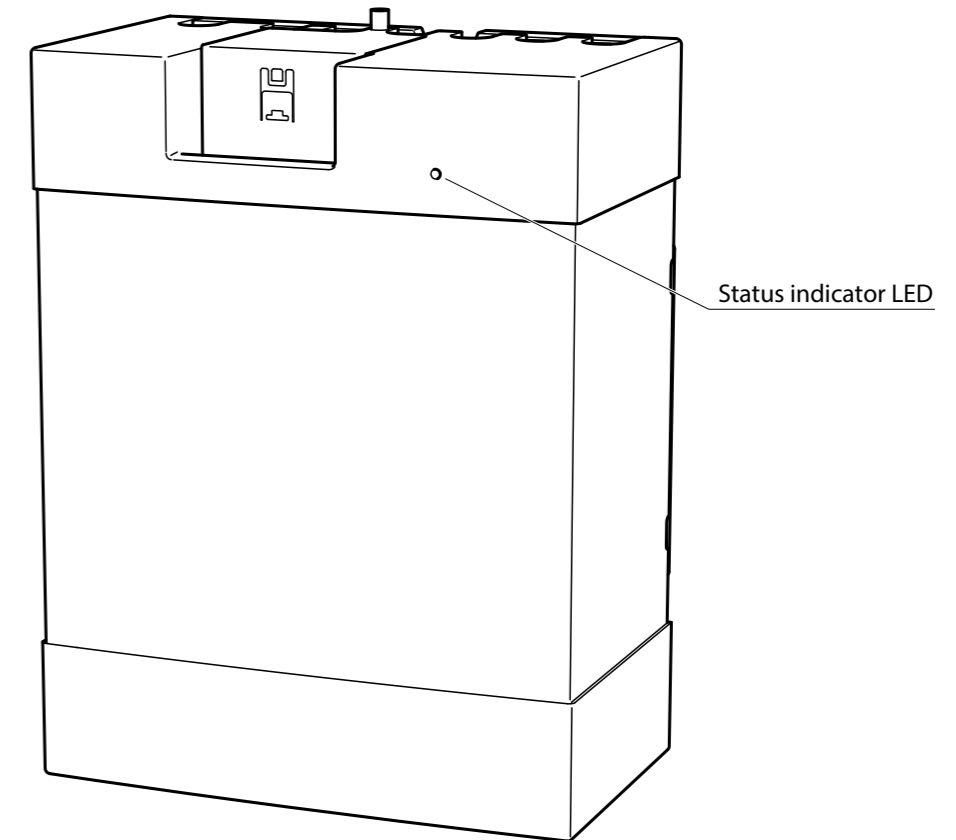

4.1 Status indicator LED

Green blinking slow (1x per second):	Stand-by condition (no SH heat demand)
Green blinking fast (2x per second):	Heating condition (CH heat demand)
Blue blinking:	Tapping condition
Red blinking:	Error mode
White continuous:	Service mode (installer only)
No LED:	No power / switched off

5. Specification

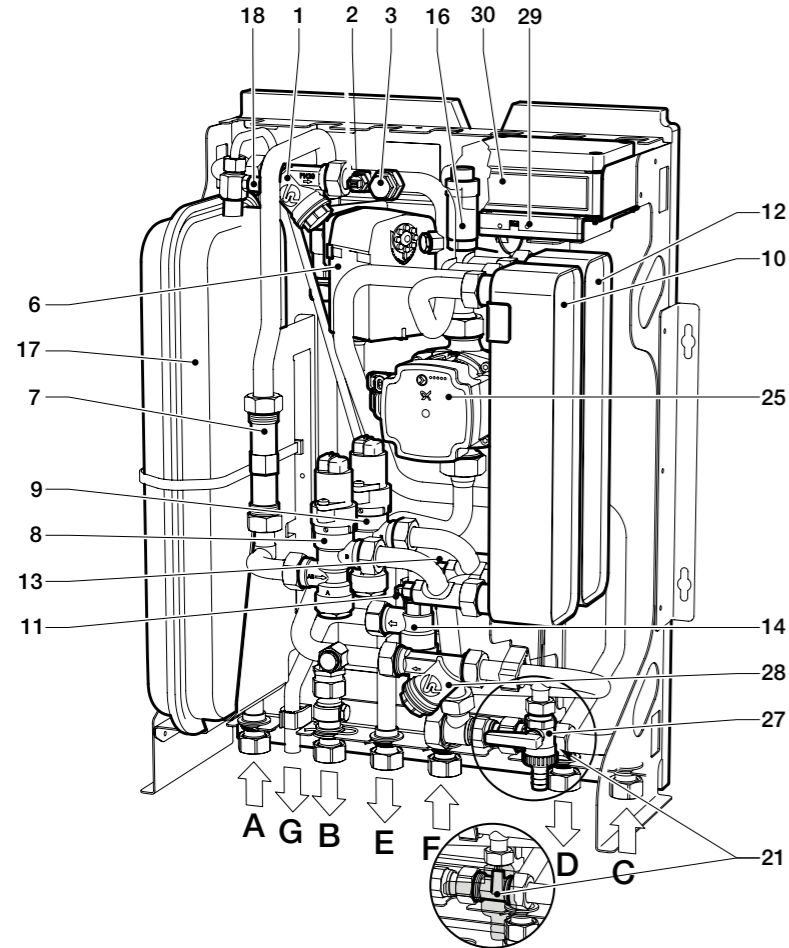

- 1 Strainer
- 2 Flow temperature Sensor (primary)
- 3 Flow temperature Sensor (heat meter)
- 4 Test point (primary, flow)
- 5 Test point (primary, return)
- 6 Spool piece (DPCV or shut off valve)
- 7 Heat meter
- 8 Control valve (DHW)
- 9 Control valve (SH)
- 10 Plate heat exchanger (DHW)
- 11 Return Temperature Sensor (primary, DHW)
- 12 Plate heat exchanger (SH)
- 13 Return Temperature Sensor (primary, SH)
- 14 Over pressure relief valve (3 bar)
- 15 Temperature/Pressure gauge (first fix rail)
- 16 Automatic bleed point
- 17 Expansion vessel
- 18 Bleed point
- 19 Water hammer arrestor
- 20 Temperature sensor (DHW)
- 21 Flow sensor
- 22 Non return valve
- 23 Non return valve (hot water return, optional)
- 24 Circulation pump (DHW, optional)
- 25 Circulation pump (SH)
- 26 Temperature/Pressure sensor
- 27 Drain point
- 28 Strainer
- 29 Controller
- 30 Power supply (mains connection)

- A Primary flow
- B Primary return
- C Cold water mains
- D Domestic hot water (DHW)
- E Secondary flow (SH)
- F Secondary return (SH)
- G Over pressure relief pipe
- H Hot water return (optional)

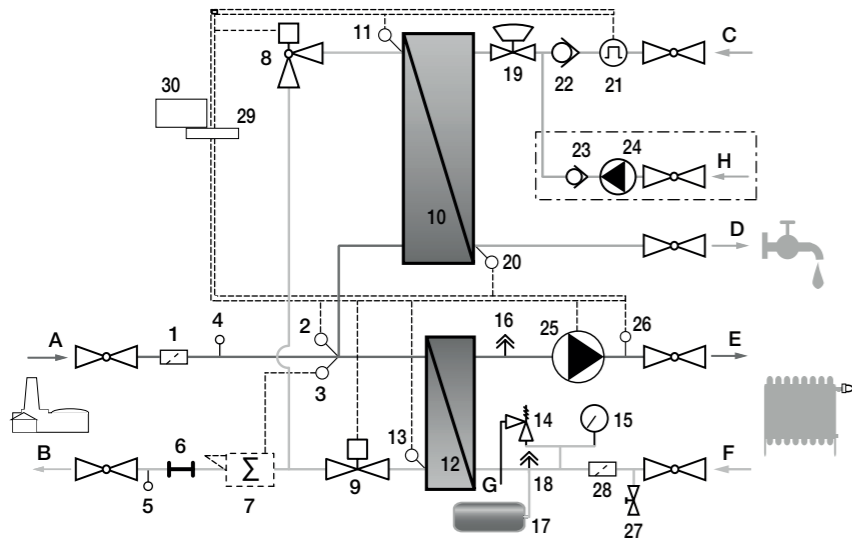

5. Specifications

5.1 Facts And Figures

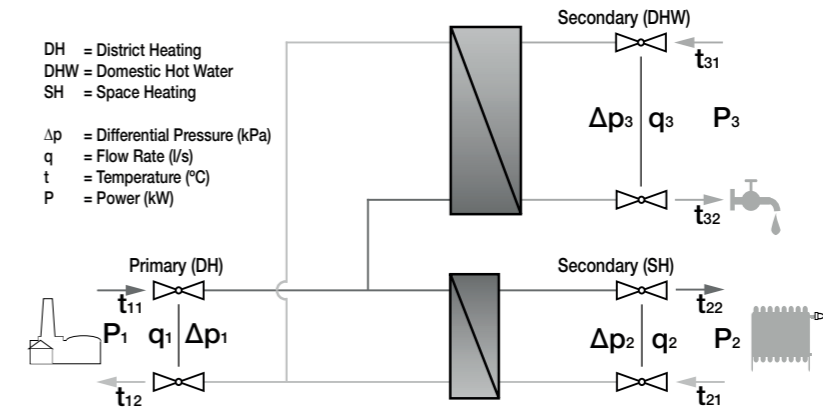

Description	Type	District heating station for indirect heating and instantaneous domestic hot water
Mounting		Wall mounted
Dimensions		490 x 275 x 640 mm (WxDxH, height of the case)
Heating System		2 pipe flow
Pipework		Copper pipe with brass fittings
Heat exchangers		Stainless steel, copper brazed
Casing		Foam Arpro 50g / White painted metal sheet banding
Primary Fluid		Low pressure hot water
Secondary Fluid - Heating		Low pressure hot water
Secondary Fluid - Domestic Hot Water		Potable hot water service
Primary Duty		
Min. / Max. flow temperature (t11)		65°C / 90°C
Nominal flow temperature (t11)		75°C
Flowrate (q1, at nominal flow temperature)		0.267 l/s (960 l/h) at max. output
Pressure rating		PN 16
Min. differential pressure (Δp_1)		50 kPa (0.5 bar), at nominal primary flow temperature
Max. differential pressure (Δp_1)		250 kPa (2.5 bar), or 450 kPa (4.5 bar) with additional DPCV
Cold Water Mains		
Min. (max.) pressure (Δp_3)		1 bar (PN 10)
Secondary Duty		
Domestic Hot Water		
Nominal Heat Transfer Capacity (P3)		63 kW
Max. flowrate (q3)		20 l/min (0.333 l/s)
Fluid Temperature in (t31)		10°C
Fluid Temperature out (t32)		55°C
Duty (secondary) Heating		
Heat Transfer Capacity (P2)		18 kW @ 30K ΔT (10 kW @ 20K ΔT), at nominal primary flow temperature
Fluid Temperature flow (t22)		Selectable: 40°C ... 70°C (at nominal primary flow temperature)
Fluid Temperature return (t21)		Depending on radiators and setup
Maximum secondary pressure		PN10 (restricted to 3 bar by over pressure relief valve)
Connections		
All external connections		3/4"
Primary & Secondary Fittings		
Primary control valves		Control valve with electronic stepper motor
Strainer		In primary flow and secondary return
Heat Meter		Prefitted - Rossweiner HeatSonic, battery powered, M-Bus interface
Circulation Pump		Grundfos UPM3 AUTO 15-70 130
Expansion Vessel		8 litre fitted in secondary circuit
Overpressure relief valve		3 bar, in secondary heating circuit
Shut off valve (optional)		Shut off valve for pre-payment systems (230V ~, 50Hz)
DPCV (optional)		Differential pressure control valve (450 kPa max. dp)
Hot water return (optional)		Hot water circulation (incl. pump, non return valve and ball valve)

6. Installation

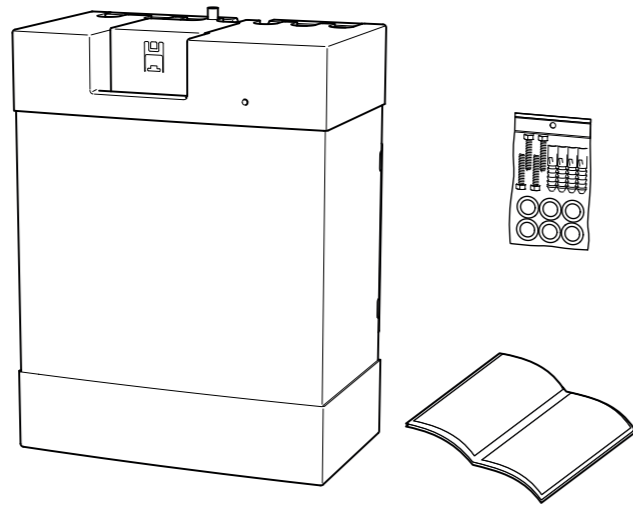

Additional items required

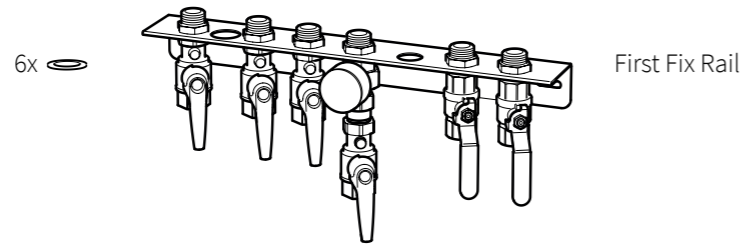

Additional Items (optional)

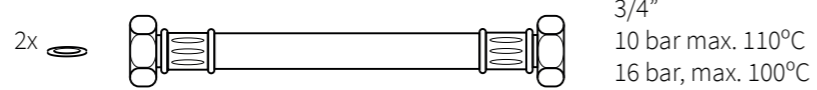

Connections

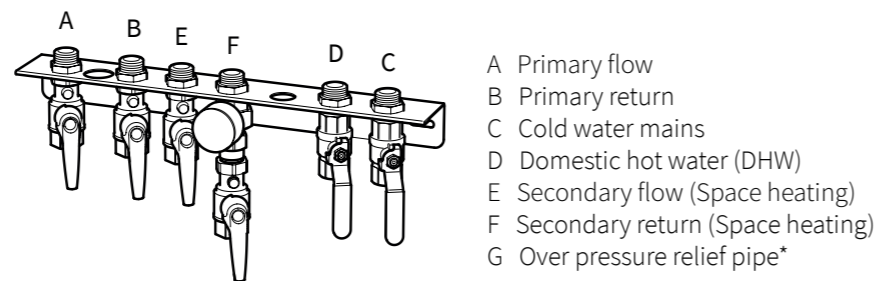

* 15mm copper pipe

6. Installation

Positioning

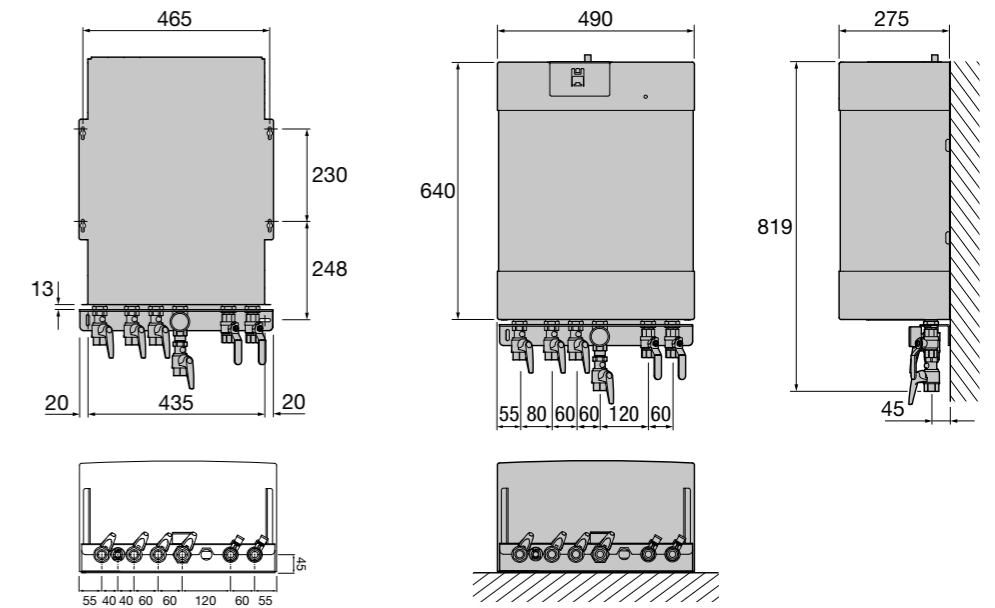

Preparation - First Fix Rail (FFR)

Mounting to the wall

The wall needs to be strong enough to support the HIU. If the wall is of drywall construction make sure that there is a board installed (e.g. plywood, min. 18mm) to support the structure, which is strong enough to hold the HIU. Use a 4mm drill bit (at least 40mm depth for the wall plugs).

If the wall is of concrete or brick construction use a 10mm drill bit (at least 60mm depth for the wall plugs).

The FFR requires 2 fixing screws, the HIU requires 4 fixing screws.

Flushing the system

Before mounting the HIU and connecting it to the FFR all pipework that is to be connected must be thoroughly cleaned and flushed out. Any debris or flux that could collect in the narrow channels of the heat exchangers will be difficult to remove once they are installed. Any remaining debris and flux may cause serious corrosion problems, as well as restricting flow and reducing the efficiency of the HIU. Use the flushing by-pass (optional accessory) and connect it to the FFR (A-B).

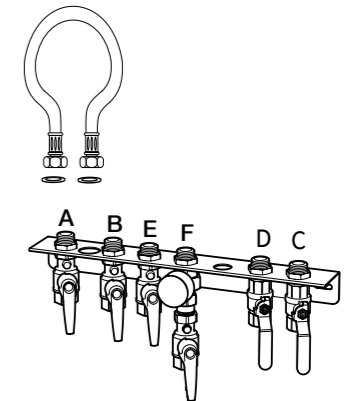

6. Installation

Installation

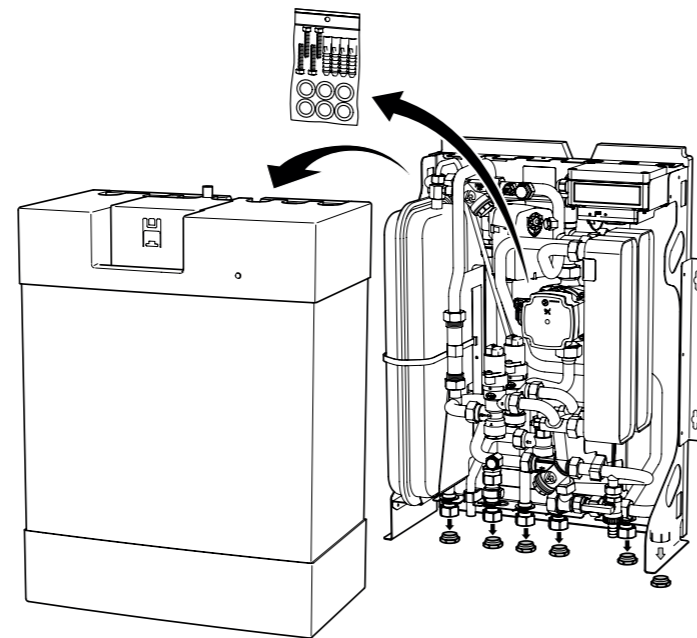

Remove the flushing by-pass before installing the HIU.

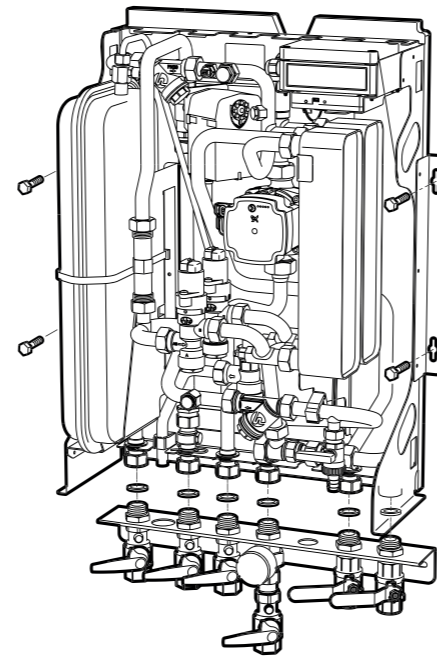
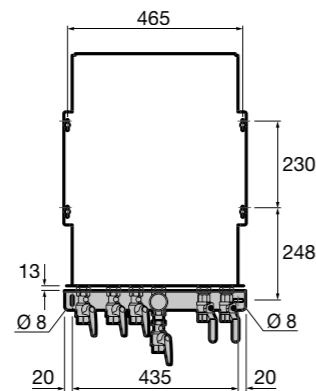

Over pressure relief pipe (G)

Over pressure relief pipe is a 15mm copper pipe. Please use suitable fittings / systems to make the connection with the drain pipe.

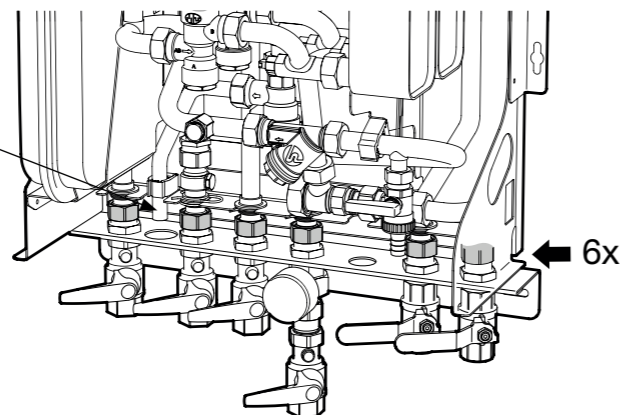

7. Service

7.1 Filling the SH

The HIU can be filled by connecting an external supply through the fill/drain valve in the unit.



Caution



Danger
Electric shock risk



Caution
Hot surface

CAUTION!

Please use caution when handling the HIU. Parts and components may be hot or energized. Contact may lead to shock, burn or electrocution.

1. Disconnect the HIU from the mains power.
2. Open all space heating circuits in the property. Turn the room thermostat and all radiator thermostats to their maximum setting. (or switch on all underfloor heating circuits).
3. Remove the case from the unit as described in chapter 7.6
4. Connect the filling hose/loop to the valve as shown.
5. Carefully open the valve and start filling the system. Observe for leaks during the process.
6. Shut the valve once the system is filled.
7. Bleed the air from the system (HIU and radiators). Please refer to chapter 7.2.
8. Repeat 6. and 7. until all air is removed and the system is pressurised according to the specifications.

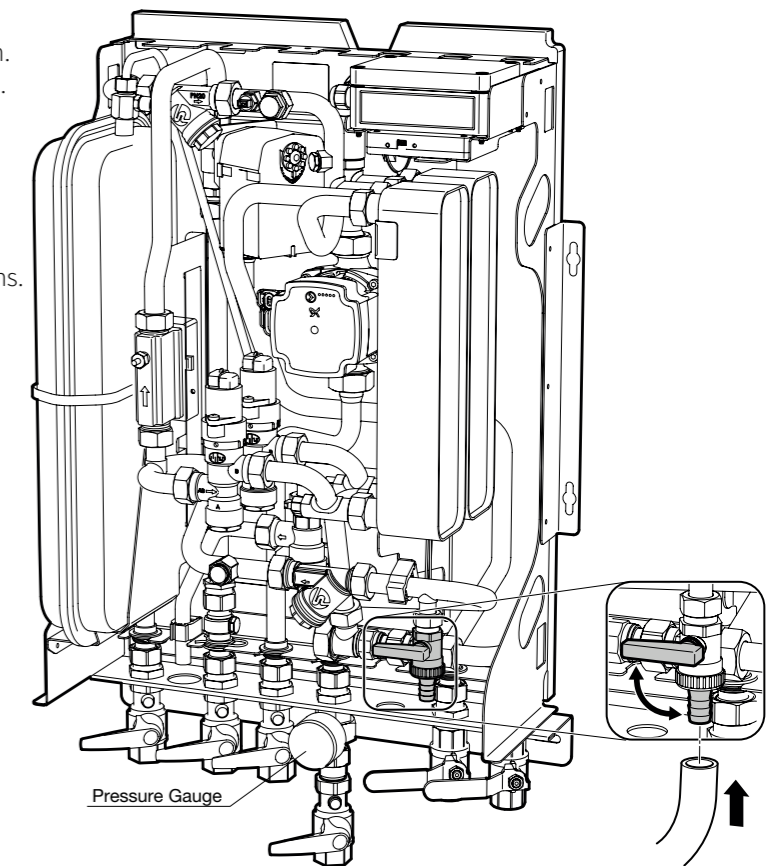

7. Service

7.2 Bleeding the air

All air has to be removed from the system to ensure full functionality of the SH. Bleeding the air can be either manually (1) or automatically (2). Also all SH circuits have to be bled to make sure all air is removed.

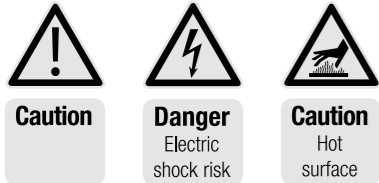

CAUTION!

Please use caution when handling the HIU. Parts and components may be hot or energized. Contact may lead to shock, burn or electrocution.

1. Disconnect the HIU from the mains power.
2. Make sure the isolating valves (E, F) are fully opened.
3. Start bleeding the SH circuits at the top floor and work the way down.
4. Set the pump to maximum speed. The pump should run quietly without any air noise.
5. When finished re-adjust the pump to its operating mode/setting.

Quick filling option:

When filling the system turn the red handle of the automatic air vent anti-clockwise. Turn on the circulation pump and let it run until all air is removed. Isolate the filling loop, re-adjust the pump setting and close the automatic air vent by turning it clockwise.

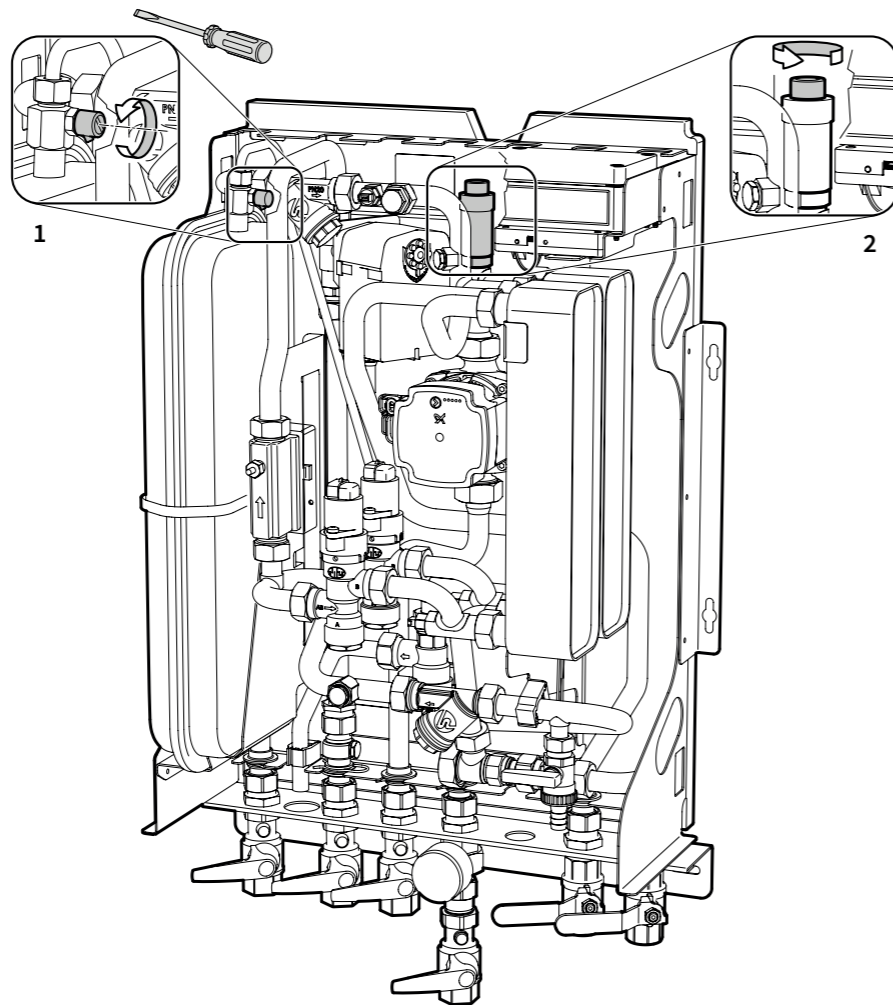

7. Service

7.3 Call for Space Heating (SH)

The unit can be connected to a room thermostat or a timer/heating controller.

The output of either of the devices needs to be a voltage-free contact (open/close). Please refer to the manual of the manufacturer of the appliance to avoid damage of the HIU's electronics.

Connecting a room thermostat or controller/timer:

1. Remove the terminal block (1)
2. Connect the two wires to the voltage-free output of the thermostat/timer/controller.

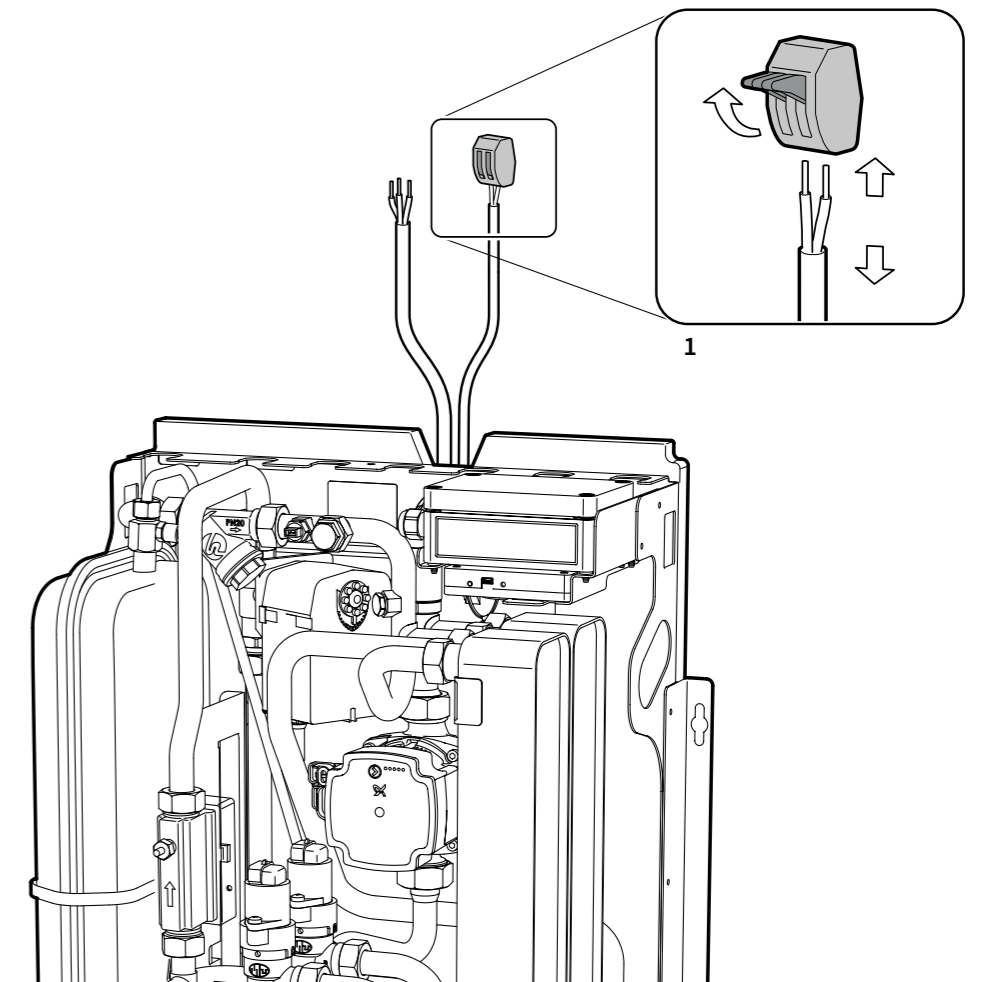

7. Service

7.4 Power supply

The HIU is equipped with an electric connection box that converts the 230VAC power supply to 24 VDC and powers the equipped SH pump and optional DHW pump. It also houses the fuse of the unit.

CAUTION!

The HIU uses electrical component (230VAC and 24VDC). Touching these components can result in an electrical shock, burn, or electrocution. The casing shall only be opened by authorised personnel when the power supply is cut off.

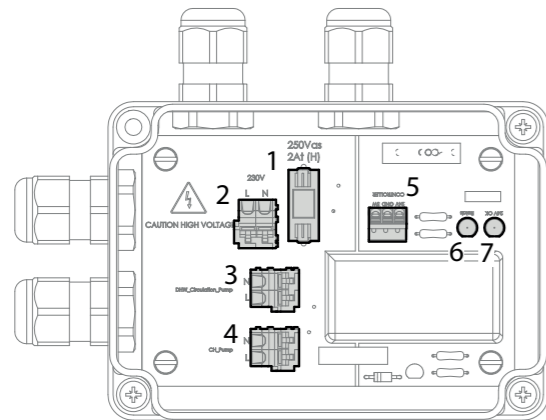

1. 230VAC fuse (3A)
2. 230VAC connection to circuit breaker or power switch
3. 230VAC DHW circulation pump connection
4. 230VAC SH pump connection
5. 24VDC connection to electronic regulator PCB
6. LED status indicator pump relay (ON = SH pump active)
7. LED status indicator 24V (ON = 24V directed to regulator PCB)
8. WAGO connector, connecting all protective earth cables

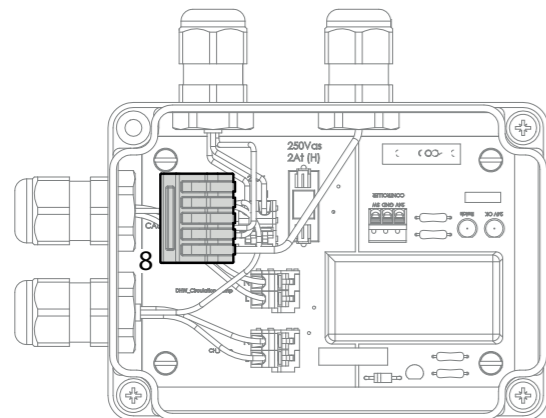

Cable colours

The electronics housing is separated into a 230VAC area and a 24VDC area. By default the following cable colours are used:

CAUTION!

230VAC area
 - Live 230VAC Brown
 - Neutral Blue
 - Protective earth Green/Yellow

24VDC area
 - 24VDC Black
 - Ground Brown
 - Signal wire Grey

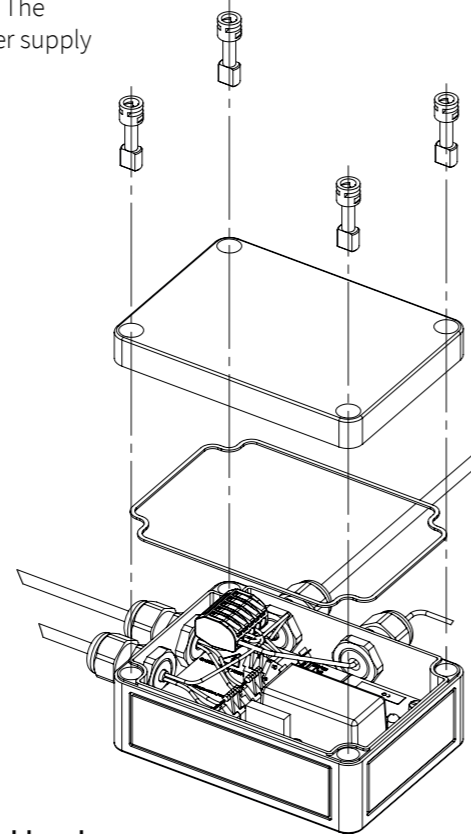
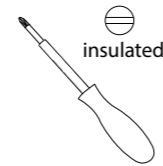

7. Service

7.5 Commissioning

Follow the steps shown below to commission the HIU. If leakage or other faults should occur, go to chapter "Troubleshoot".

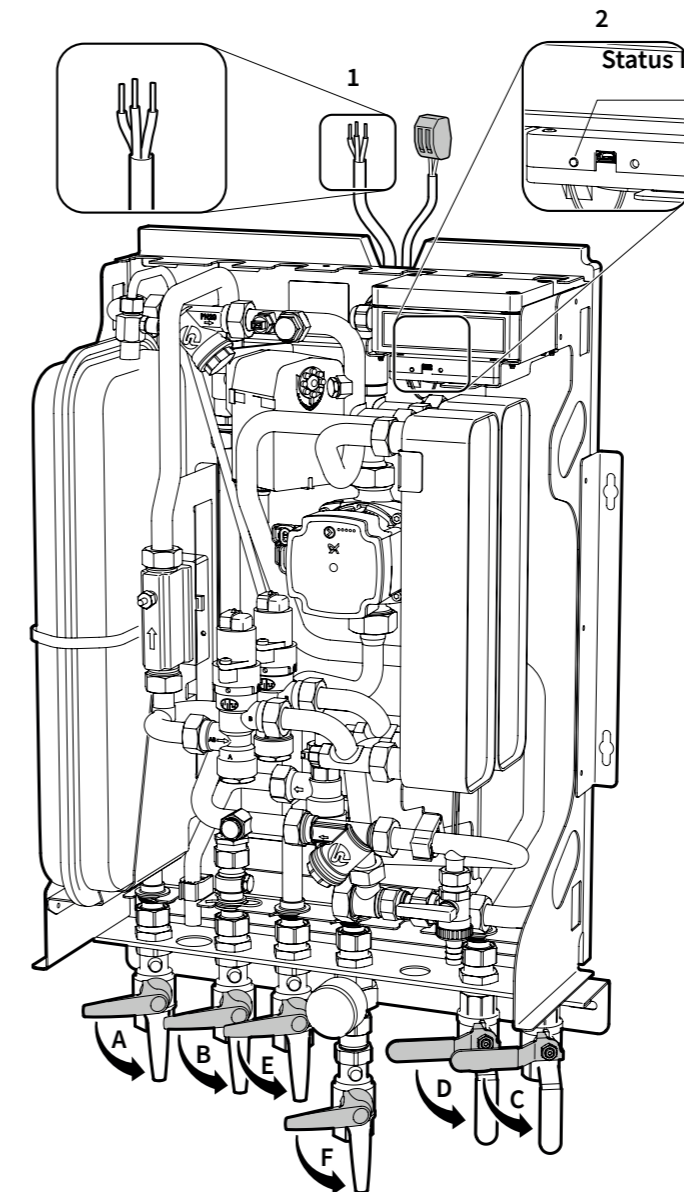

CAUTION!

Parts and components may be hot or energized. Contact may lead to shock, burn or electrocution.

1. Close all valves
2. Check all nuts for leakage. (nuts may become loose during transport)
3. Make sure the electronics are securely mounted to the frame and avoid cables from blocking the casing.
4. Make sure that the power supply is switched off. Connect the unit's power cables (1) to the power switch. **Keep the power switch off, until further notice below.** The power switch must be permanently connected, suitably located and easily reached. Also see chapter "Installation requirements"
- Blue cable: N (neutral)
- Brown cable: L (Live 230VAC)
- Green/yellow: PE (protective earth)
5. Open the domestic potable water valves (D&C) to pressurise the unit and check for leakage.
6. Switch on the power to the unit. The LED should show a green blinking light (2).
7. Open the DH valve (A) and check for leakage.
8. Open the DH return valve (B) and check for leakage.
9. Open the valve (E).
10. Open the SH return valve (F).
11. Start bleeding the SH circuits at the top floor and work the way down. (see also chapter "Bleeding the air")
12. Check to see if the heating warms up.
13. It is possible to set the pump setting to optimise the SH system. See chapter "Pump settings".
14. Completely open a DHW outlet (tap or shower). Check to see if the unit's LED shows a blue blinking light (2). Leave it running for approximately 5 minutes. Check if the DHW temperature has reached its set point (default 55°C) between 3 and 5 minutes.
15. Close all DHW outlets. The LED will now show a green blinking light (2).

7. Service

7.6 Removing and securing the case

The case of the HIU is secured by the mounting bracket of the heat meter display and a screw through the top of the HIU.

1. Mount the display of the heat meter (if needed) to the bracket.
2. Position the bracket as shown (1) and make sure all cables are routed through the case and are tidy.
3. Make sure that bracket and case are in line to fit the securing screw (2).

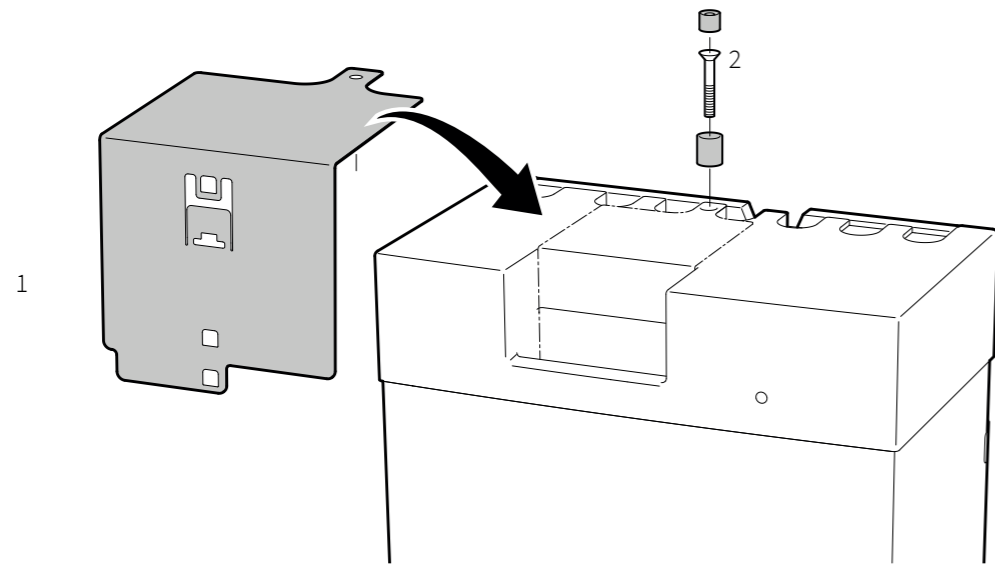

7. Service

7.7 Grundfos pump

The Grundfos pump has 3 control modes (proportional pressure, constant pressure and constant curve). Each control mode has 4 settings to choose from. The user interface has one push button, one red/green LED and four yellow LEDs.

SETTING OPTIONS

PROP.PRESS.:CURVE 1	
PROP.PRESS.:CURVE 2	
PROP.PRESS.:CURVE 3	
PROP.PRESS.:AUTO ADAPT	
CONST.PRESS.:CURVE 1	
CONST.PRESS.:CURVE 2	
CONST.PRESS.:CURVE 3	
CONST.PRESS.:AUTO ADAPT	
CONST.CURVE.:CURVE 1	
CONST.CURVE.:CURVE 2	
CONST.CURVE.:CURVE 3	
CONST.CURVE.:CURVE 4	

Default setting

Push button

Settings

You can choose between the performance view and settings view. If you press the push button for 2 to 10 seconds, the user interface switches to "select selection" if the user interface is unlocked. You can change the settings as they appear. The settings appear in a particular order in a closed loop. When you release the button, the user interface switches back to the performance view and the last setting is stored.

7.8 Performance view

While the pump is running, the first LED will show a green light. The following four LED's will indicate the power consumption as shown in the table below.

Stand-by (only externally controlled)	0%	
Low performance	0 - 25%	
Medium performance	25 - 50%	
Medium High performance	50 - 70%	
High performance	70 - 100%	

7. Service

7.9 Hot Water Circulation



Caution



Danger
Electric
shock risk



Caution
Hot
surface

The domestic hot water circulation pump is an available option within the unit. The pump is added to minimize delay in the delivery of domestic hot water at the draw off point in a closed DHW circulation circuit. It is generally used in systems where the domestic hot water needs to travel greater distances to its draw off point.

Adjustments to the pump settings should be done by authorised personnel only. Please use caution when adjusting the unit. Parts can be hot or energized. Contact may lead to shock, burn or electrocution.

Status indicator LED

LED on (continuously):	Normal operation (pump is running)
LED blinking short, long:	Error due to low voltage
LED blinking short (4x), long:	Error due to pump speed feedback
LED blinking short (3x), long:	Error due to high temperature
LED blinking short (5x), long:	Pump rotor is blocked
LED On 200 msec., Off 200 msec., On 200 msec.	Air venting
LED On 50 msec., Off 50 msec., On 50 msec.	Stand-by

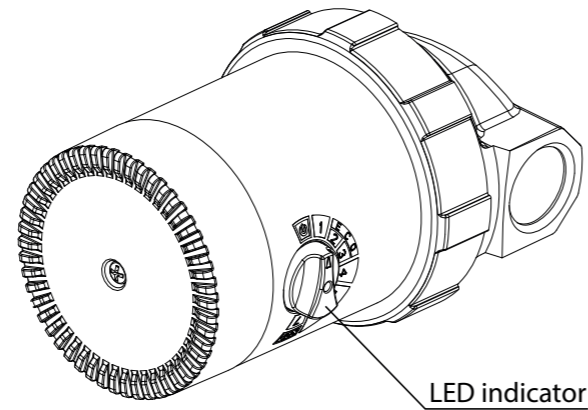

LED indicator

Operation errors

Problem	Cause	Solution
Pump not running	- Not connected or connected correctly	- Connect correctly
	- Pump too hot, dry operation- or overheating protection active	- Allow pump to cool down, pump restarts automatically
	- Pump blocked	- Contact your supplier
Pump is noisy	- Air in the system	- Bleed the air
	- Debris in pump	- Contact your supplier
	- Worn bearing	- Replace pump

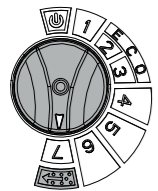

Air bleeding the pump

The pump has an air venting function that can be activated by turning the dial to position 7 for 5 seconds. Afterwards the desired position can be chosen. The procedure will take about 10 minutes. The procedure can be cancelled by switching to position 3 and then back to position 7. Audible flow noises indicate that there is still air in the pump. Should this be the case the air bleeding procedure needs to be repeated.

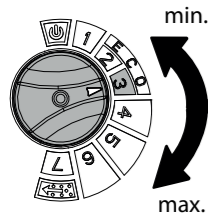

Pump settings

The circulation pump has 7 settings to choose from to accommodate different situations, position 1 being the lowest and 7 the highest setting.

7. Service

7.10 Differential Pressure Control Valve



Caution



Danger
Electric
shock risk



Caution
Hot
surface

For DH systems with a differential pressure exceeding 250 kPa (with a maximum of 450 kPa), the option of a factory fitted adjustable differential pressure control valve is available. The differential pressure control valve has a control range of 20 to 60 kPa and has DN20 bore. For optimal functioning of the HIU, the adjustable differential pressure control valve is set at its maximum of 60 kPa (default setting).

Adjustments to the valve settings should be done by authorised personnel only. Please use caution when adjusting the unit. Parts can be hot or energized. Contact may lead to shock, burn or electrocution.



HEX 4 mm

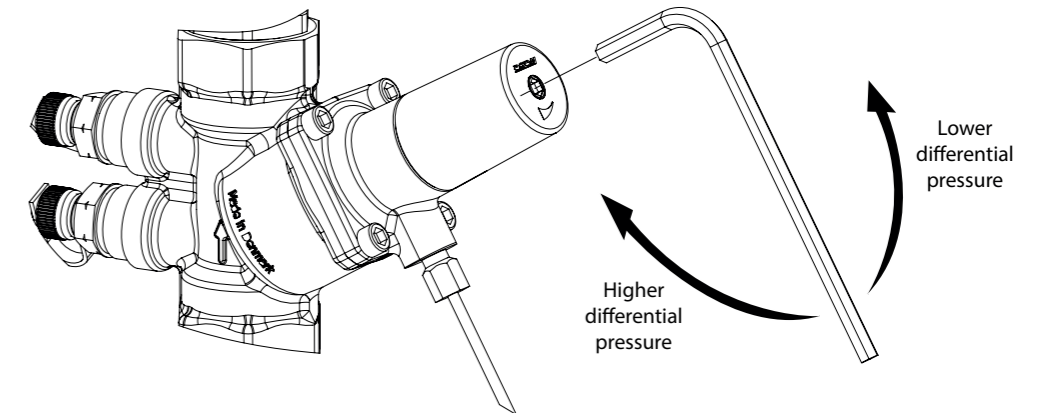

The valve is easily set by means of a 4 mm allen key. The maximum setting of 60 kPa is reached by turning the hexagonal key clockwise. The number of turns needed to adjust the valve to its maximum setting depends on what the current setting is. The maximum number of turns is 20, running from its minimum to maximum setting.

7. Service

7.11 Heat Meter

The HIU's factory fitted heat meter is an MID class 2 (RHI certified), battery powered ultrasonic heat meter with M-Bus functionality. You can scroll through the menu by shortly pressing the black button next to the display. The serial number (8 digit number) can be found as shown in the picture.

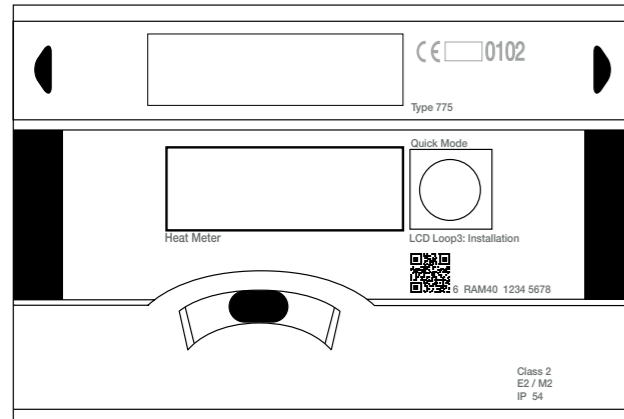

Error code	Description
C -1	Basic parameter error in flash or RAM
E1	Temperature range exceeded [-19.9 °C ... 199.9 °C] e.g. sensor cable short circuit
E 3 **	Flow and return sensors inverted/confused
E4	Hardware fault in ultrasonic unit, e.g. transducer or trigger faulty or short circuit
E5	Reading interval too short. No communication possible.
E 6 **	Wrong flow direction (flow sensor)
E7	Undetermined flow sensor reading (air, debris)
E8	No (mains) power supply, running on the backup battery
E9	Battery discharged
E A*	Leakage, broken pipe
Eb *	Leakage, heat meter
EC *	Leakage, pulse input 1
Ed *	Leakage, pulse input 2

* optional, ** application dependent

The Table shows the list of error codes which might be shown on the display. "E-7" is the general error that is shown when the HIU has not been filled (air in flow sensor).

For further information please refer to the leaflet of the heat meter (Installation Guide) supplied with the HIU or refer to the comprehensive manual for the heat meter.

7. Service

7.12 Troubleshoot (technician)

Complaint	LED indication light	Cause	Solution
Leakage Close all valves on the fix rail and close the main water supply valve.			
Coupling nut shows leakage		Coupling nut is loose Gasket is missing	Fasten coupling nut Replace gasket
Temperature sensor shows leakage		O ring is missing O ring is damaged	Fit original Replace original
The differential pressure pipe from the differential pressure regulator is leaking		Coupling is loose Differential pressure pipe is damaged	Fasten the fitting Replace differential pressure pipe
Space heating does not warm up			
Radiator does not warm up	LED does not light up	No power at power source	Check power source
		Unit is not connected to power source	Connect the unit to the power supply
		Power cables not properly connected to electronic regulator	Connect the power cables to the electronic regulator
		Fuse is broken	Check for any short-circuit problems and replace fuse (3A)
		Failure in the electronics	Contact your supplier
	Blue flashing LED	Tap is opened, unit is in tapping operation	Close Tap
	Red flashing LED	Sensor(s) are not connected or bad contact	Check wire tree connections and connect the sensors properly, then restart electronics
		Sensor(s) defect	Replace broken sensor and restart electronics
		Possibly faulty electronic cables or electronics	Contact your supplier
	White flashing LED	Unit is in service mode	Remove USB cable Reset the unit by removing and then reconnecting the power supply
		No heating demand from the room thermostat	Set the room thermostat to a higher temperature than the actual room temperature
		Radiator valves are closed	Open radiator valves
		Valves in first fix rail are closed	Open valves on first fix rail
		Thermostat cable not properly connected to room thermostat	Make sure the room thermostat is connected properly
		Short circuit connector of the room thermostat is not connected or missing (when HIU is not connected to room thermostat)	Connect the wire ends of the room thermostat connection cable with a short circuit connector
Air in the SH system		Air vent the HIU and the SH system	
Pressure in SH circuit is too low		Set SH pressure to 2 bar. This might indicate a leakage in the SH system or a broken expansion vessel. Check SH system for any leakages and expansion vessel	
Pressure or temperature of the DH system are not in accordance with specifications		Check temperature and pressure of the DH system	
The SH pump is not active (LED on pump does not light up)		Check if the pump cable is properly connected to the electronics	
The SH pump is jammed or broken	Contact your supplier		
Optional anti-fraud valve is closed	Anti-fraud valve is not electrically connected or powered	Anti-fraud valve is not electrically connected or powered	
	Anti-fraud valve is jammed or broken. Replace this component	Anti-fraud valve is jammed or broken. Replace this component	
Optional differential pressure valve is poorly adjusted	Adjust the differential pressure valve correctly		
Filters are blocked	Check and clean filters		
SH heat exchanger is blocked	Replace SH heat exchanger		
Cables of the control valves are mixed up	Connect cables properly. Orange/red connector must be connected to the SH control valve		
Possible defect in control valve	Replace control valve		

7. Service

7.12 Troubleshoot (technician)

Complaint	LED indication light	Cause	Solution
No DHW			
No DHW		No water pressure	Check/open main water supply valve Check flow restrictor for correct and proper placement Flow restrictor is clogged or jammed. Replace flow restrictor Flow sensor is clogged. Replace flow sensor DHW heat exchanger is clogged. Replace DHW heat exchanger Check valve is jammed. Replace check valve housing including the check valve
DHW not at the right temperature			
DHW does not warm up	LED does not light up	HIU is not connected to power source	Connect the HIU to the power supply
		No power at power source	Check power source
		Power cables not properly connected to electronic regulator	Connect the power cables to the electronic regulator
		Fuse is broken	Check for any short-circuit problems and replace fuse (3A)
		Failure in electronics	Contact your supplier
	Green flashing LED	Tapping threshold is too low, minimal 1 L/min. has not been reached	Increase tapping to at least 2 L/min. by opening the tap further
		Flow sensor is not installed correctly	Check flow sensor, replace cable or replace flow sensor
	Red flashing LED	Sensor(s) are not connected or lose contact	Check loom connections and connect the sensors properly, then restart electronics
		Sensor(s) defect	Replace broken sensor and restart electronics
		Possible defect electronic cables or electronics	Contact your supplier
		Supply and return valves are closed	Open supply and return valves
		Pressure or temperature of the DH system are not in accordance with specifications	Check temperature and pressure of the DH system
		Filter is clogged	Check and clean filter
DHW heat exchanger is clogged		Replace DHW heat exchanger	
Cables of the control valves are mixed up		Connect cables properly. Green connector must be connected to the DHW control valve	
Possible defect in control valve		Replace control valve	
Option: DHW circulation circuit does not warm up	LED does not light up	Fuse is broken	Check for any short-circuit problems and replace fuse (3A)
		Power supply cable of the optional DHW circulation pump unit is not connected	Connect the power supply cable of the optional DHW circulation pump unit
		Optional DHW circulation pump unit is broken or jammed	Replace DHW circulation pump unit
		Failure in electronics	Contact your supplier
Casing will not close properly			
Casing does not close properly		Cables are caught in between unit and casing	Keep cables free of any obstructions
		Metal bracket holding the heat meter is not fitted correctly	Adjust / fit bracket and try again
		Heat meter is obstructing the casings path	Connect the heat meter properly
		Electronics are not properly placed	Check mounting of electronics
Other defects It is normal for the HIU to generate a light noise during tapping or heating operation. The regulator valves can also make a light humming sound			
Rattling sound	Red or green flashing LED	Flow sensor not installed correctly	Install flow sensor properly
Other defects			Contact your supplier

8. Appendix A

Guidelines for System Conditioning of Heating and Cooling Networks for Flamco Limited - LogoEco Heat Interface Units (HIU)

Flamco Limited prides itself on bringing to the UK market a proven range of Heating and Cooling Interface Units. To ensure that our products deliver increased longevity and performance, these guidelines are specifically written to aid and ensure both the primary and secondary side of the heat network are designed, installed and commissioned to realise the desired heating comfort levels. **These guidelines are not offered for use on potable, domestic, and water draw off side of the system. Solely for the heating and cooling circuits ONLY. For further guidance on water treatment and water analysis please refer to BSRIA BG29/2012, BG50/2013 and BS8552.** Whilst not exhaustive, we offer these guidelines from experience and a practical standpoint, in addition, as a check list to support design review. These guidelines are not intended as mandatory or fixed in their approach; moreover they are intended as supporting documentation to highlight good practise and methodology ensuring operation and maintenance activities are kept to a minimum post handover. We are not specialists in the design, installation and or cleaning and subsequent treatment of water systems but, nevertheless, contained in the sections below are importance aspects to consider.

8.1 System Design Considerations

- A review of the system should be undertaken post the design stage. The review should focus on the installation, location and capacity of strainers both fixed and temporary, air and gas removal devices, debris traps, isolation valves to ensure that removal of debris from the system which was not removed in the commissioning activity is managed and that sub sections can be economically isolated to permit maintenance.
- It should be considered at the design stage to include into the design a means ferrite removal. Poorly commissioned and maintained systems exhibit corrosion. As the majority of systems contain products manufactured from iron, it is the iron in the form of steel ferrite which creates the tell tale black sludge or blacked water which indicates corrosion is taking place of components of the system. This corrosion if remaining unchecked, fouls water ways and controls, erodes system components, reduces system performance and leads to the production of hydrogen in the system known as "Gassing". This is also a tell tale sign of system corrosion.
- As over 90% of debris in systems is ferrous we recommend the installation of a rare earth, magnetic filter to both remove the ferrite but act as a means of identifying corrosion is taking place and a prompt for remedial action.
- The removal device ideally, should have a first pass rate of 75% debris removal or greater, have incorporated into it a static mixing function to open the system fluid to permit rapid removal of the debris, mounted in the common return, main return pipe work. The filter shall be of adequate size and capacity to allow sufficient flow rate and debris capture for the system size (line size is recommended). Any such filter should have the following magnetic field strength capacity as a minimum to ensure maximum ferrite removal.

Line Size	Magnetic Field Strength
DN15	7500 gauss
DN20	9000 gauss
DN25	10500 gauss
DN35	21000 gauss
DN40	21000 gauss
DN50	52500 gauss
DN80	73500 gauss
DN100	73500 gauss
DN150	94500 gauss

The filter should be added to the requirements of the "Operating and Maintenance" instructions handed over with the system. If an advisory sticker is provided with the filter it should be attached at a suitable location as to indicate the presence within the system of the filter to ensure periodic checking & servicing by any attending Service Engineer. We would also recommend that these filters incorporate a sight glass, particularly on the larger sizes to provide a visual means of assessing corrosion without the need to disrupt the operation of the system for checking.

8. Appendix A

8.2 Main Factors affecting corrosion and System performance

- “PH” or relative Acidity/ Alkalinity are of key importance in managing the production of system corrosion. It is recommended that PH Level of the system water be between 7 and 8.5 (ideally 7.4/7.5). A Lower PH level than recommended would be classed as acidic and corrode all metals. Alternatively, too high a PH level would be alkaline and will corrode aluminium components within the wetted part of the system.
- When considering a chemical treatment product to add to the system, we recommend products which incorporate a mix for buffering, in order to control the PH level more effectively.
- Oxygen Ingress should be minimised by the use of closed systems and barrier pipe within the system design.
- Aggressive ions (such as flux residues) promote corrosion and, continue to do so unless neutralised or flushed out completely. We would recommend a jointing approach that removes the need to use such compounds and adopt the use of heat free systems.
- If traditional solder fittings are used then we would recommend the use of a recognised chemical treatment to flush out and neutralise the system (see section 3.1 below). In addition, it is strongly advised to contact the manufacturer of the chemical treatment to gain early involvement prior to treatment as to the correct application and chemical to use.
- The accumulation of sludge & debris can cause deposit corrosion which leads to pitting. We recommend the use of a recognised chemical treatment to flush out and neutralise the system. In addition, it is strongly advised to contact the manufacturer of the chemical treatment to gain early involvement prior to treatment as to the correct application and chemical to use.

8.3 Refurbishment and Improvement to existing systems

- It is vitally important that before commencing works on existing systems that a complete scan of the water quality of the system be taken. If it is found that the system contains products of corrosion and/or PH levels in excess of the required norms, it is recommended that the existing water is conditioned and treated PRIOR to the work commencing.

8.4 System commissioning (water quality) Water Treatment Chemicals

- We do not recommend the use of raw water for hydraulic testing due to the risk of corrosion of the water being left in the system and potentially, the internals of the system being exposed to the air due to partial draining.
- Chemically dosed water should be in all filling activities in accordance with the chemical manufacturers’ recommendations and in accordance with BSRIA BG29 2012.
- After a suitable filling and flushing regime is used, relevant to the system material, all chemicals used to be suitable for HIU must comply with EU norms DIN EN 12828 and current guidelines for heating systems. In addition, they should also be non hazardous, non toxic and biodegradable.
- The use of correct cleaners and inhibitors is of primary, environmental concern. All chemicals used to treat the system should not contain phosphates, sulphuric acid, nitrites. See BS7593:2006 Code of Practice for treatment of water in domestic hot water space heating systems.
- Inhibitors should meet Buildcert as a minimum and preferably be recommended by the Energy Savings Trust (ESR).
- Acid based cleaners are unsuitable for older systems as there is a risk of “pinholing” on radiators. They will also require some form of neutralisation process before being discharged or require being taken away for disposal.

8. Appendix A

8.5 Recommendations for system conditioning - (Basic process)

- The system must be flushed and inhibited in accordance with BS7593 and the Domestic Building Services Compliance Guide.
- The chemicals used should contain the following aspects of their composition:
 - Surfactants to reduce surface tension allowing chelating agents to attach to the residues.
 - Chelating agents will then entrap the calcium carbonate within the solution.
 - Dispersant’s are used to hold residues in suspension.
 - The inhibitor then prevents corrosive attacks on metals during cleaning.
 - PH Buffers to maintain a neutral PH.
 - Chemicals shall be of a type suitable for disposal through a conventional sewer or foul drain (i.e. no requirement for tankering or specialist disposal).
 - Neutralisation.
 - For cooling applications, specialist chemicals and advise should be sought.

8.6 Site installation conditions – Installation of the system

It is recommended that:

- Water soluble flux should be used (no Chloride – COSSH) therefore “heat free” systems are recommended.
- The area of installation should be free from gypsum dust, brick dust, screed or other possible contaminants.

8.7 Recommended aftercare (HIU) Network Primary side

- Any relevant details of the installed units and system conditioning to be documented in the O&M manual.
- There should be clear notification of any chemical products added, dates etc placed on the HIU.
- If there is a requirement for a partial drain down, the inhibitor should be topped up to the required level with full details.
- We highly recommend that all servicing/inspection etc as per manufacturer’s instructions (HIU, filter, chemicals etc) is fully adhered to.
- Any checklist sticker placed within the casing by the manufacturer must be completed.

8. Appendix A

8.8 Recommended aftercare (Network)

It is recommended that a regime of periodic inspection of the system be undertaken. The inspection shall take the form of:

Visual inspection

System visual inspection, exterior corrosion, water stains on the pipe work and equipment, suggesting a slow leak and make up water entering the system thereby diluting the inhibitor concentrations.

Water Samples

Water samples shall be drawn from a suitable draw off point to ascertain the condition of the network, on the primary side water.

The analysis of the water should include:

- Visual assessment – Note any discolouration away from clear as an indicator of possible corrosion
- Chemical assessment – PH value, hardness, precipitate composition and concentration of chemical treatment and type of treatment contained within the water (A UKAS registered lab is recommended to be used in the system water analysis).

8. Appendix B

Example wiring of a pre-payment system (GURU Systems)

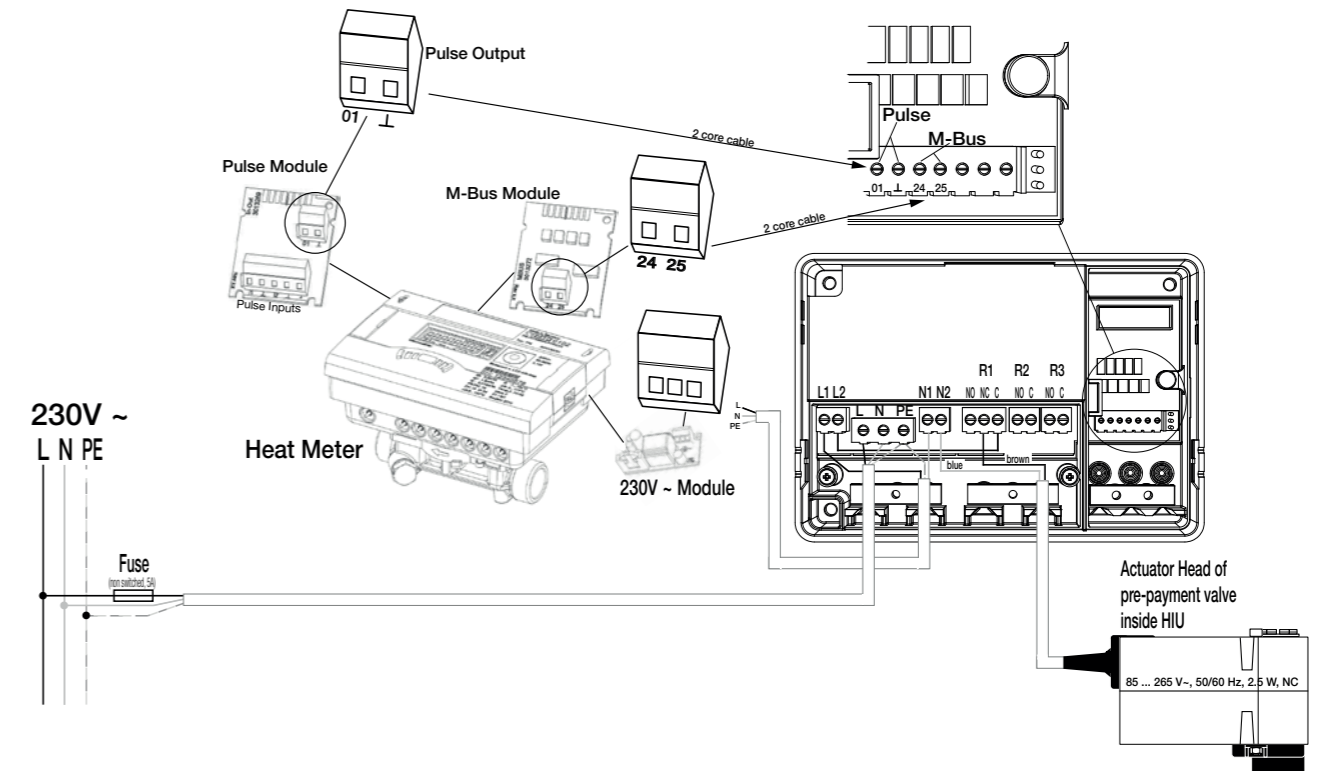

8. Appendix C

Spare parts

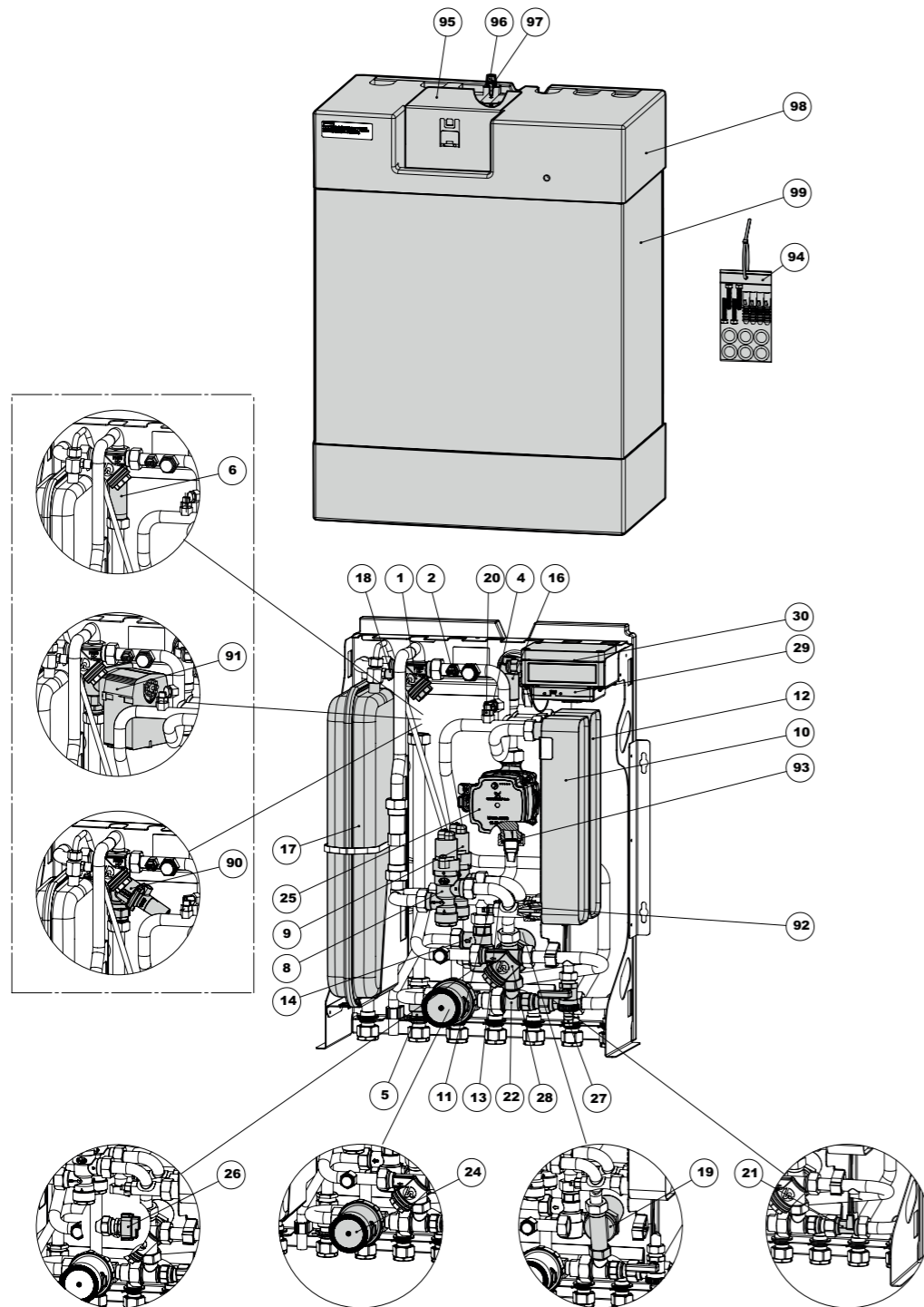

Spare parts

Key	Description	Detail
1 & 28	Y Strainer	G3/4" BT x G3/4" BT L=82 PN20
2 & 20	Temperature sensor	NTC 10K3 1/8" BSP ø4.7x17
4 & 5	Pressure test point	
6	Spool piece 110mm	G 3/4" x G 3/4"
8 & 9	Control valve	VDE/ML SIN.ø9.5 24V 50Hz
10 & 12	Plate Heat Exchanger	E8LASHx40/1P-SC-S 4xG 3/4" BT
11 & 13	Temperature sensor	NTC 10K3 1/8" BSP ø5-6 x 90
14	Over pressure relief valve	PRESCOR Rp 1/2" 3 BAR
15	Pressure gauge	0-4BAR / 0-120°C
16	Automatic bleed point	MS G3/8" BT
17	Expansion vessel	G 3/8" BT 8 LTR
18	Bleed point	G 1/8" BT
19	Water hammer arrester	G 3/4" WM x G 3/4" BT l=84,5
21	Flow sensor	SIKA
22	Non return valve	
24	circulation pump, DHW	Lowara
25	circulation pump, space heating	Grundfos UPM3 AUTO 15-70 130
26	Temperature/pressure sensor	RPD 0-6 BAR
27	Drain point	
29 & 30	Controller & Power supply	
90	Differential pressure control valve	2xG3/4"BN 20-60 kPa DN20 PN25
91	Shut off valve + actuator	R2015-S1 + TRF230NC
92	Seal	SENTINEL ø24 x ø16,2 x 3
93	Seal	SENTINEL ø29 x ø20 x 2
94	Wall mounting kit (wall plugs, screws, Washers)	
95 & 96 & 97	Heat meter mounting kit	
96 & 97	Mounting screw & anti-tampering cap	
96	Securing screw	ø6
98	EPP case	EPP TYPE 9335
99	Steel sleeve	White coated

Flamco Limited

Washway Lane

WA10 6PB St. Helens

Merseyside

United Kingdom

T +44 17 447 447 44

F +44 17 447 447 00

E info@flamco.co.uk

I www.flamcogroup.com

