

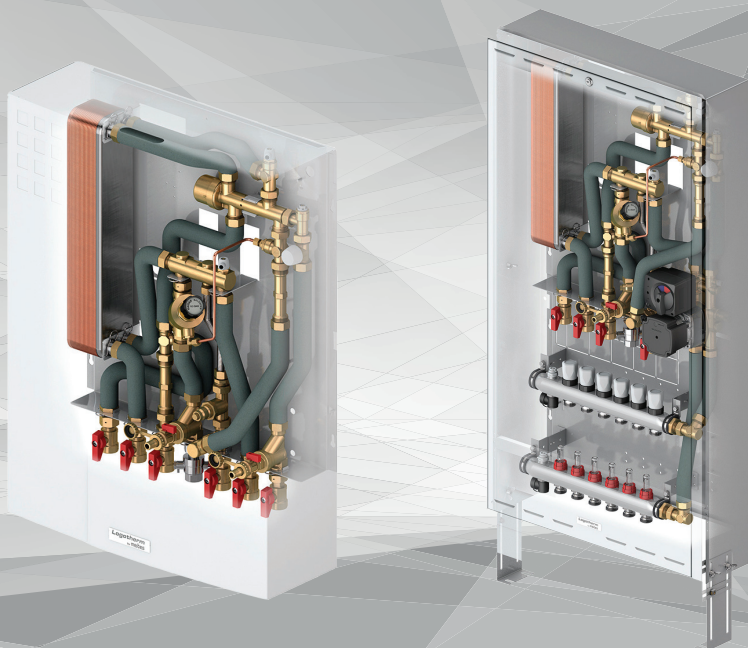

Logotherm

LogoComfort 500, 600 und 600+

as well as LogoComfort thermal heat exchangers BE 500, 600 and optional components



ENG Installation and servicing instructions



Abbreviations

LC	LogoComfort
BE	Thermal heat exchanger
CW	Domestic water, cold
DHW / HW	Domestic hot water
DWC/C	Domestic water circulation
DW	Domestic water
FL	Heating flow line
RL	Heating return line
UC/RH	Unmixed heating circuit, static heating circuit for e.g. radiators
MC	Mixed heating circuit
UFH/UFM	Underfloor heating circuit / manifold
HC	Heating circuit
PHE/HE	Plate heat exchanger
CU	Copper-soldered
ES	Stainless steel-soldered
FT	Female thread
MT	Male thread
primary	Primary heating circuit (heat supply)
sec.	Secondary heating circuit (heat consumer)
HFM	Energy meter
SM/FM	Surface-mounted / flush-mounted
SMC/FMC	Surface-mounted / flush-mounted cover
HE	High-efficiency pump
BV	Ball valve
WxHxD	Width, height, depth

Table of Contents

Abbreviations	2
1. Safety instructions.....	5
1.1 Intended use	6
1.2 Device designations.....	7
1.3 Hazard notes	7
1.4 What to do in the event of a breakdown or leaks.....	8
1.5 Spare and wear parts.....	8
1.6 Requirements on trained engineers.....	9
1.7 Liability and copyrights.....	9
1.8 Earth bonding or protective earthing in accordance with VDE.....	9
2. Functional description	10
3. LogoComfort stations.....	11
3.1 LogoComfort 500/ 600 and 600+ as base stations.....	11
3.2 LogoComfort 500/600 and 600+ as prefabricated stations.....	22
3.3 LogoComfort complete stations (CS).....	26
3.4 LogoComfort thermal heat exchanger (BE) 500/600 mm wide.....	28
4. Installation.....	31
4.1 Installation notes using the example of the flush-mounted cover for LC 500/600 and 600+ ..	32
4.2 Mounting rails and assembly aids for surface and flush mounting (optional accessories)	33
4.3 DN20 straight-way ball valves (add-on elements)	35
4.4 Top connections (add-on element)	36
4.5 Installation of optional components (depending on variant)	36
5. Description of individual components and setting options	39
5.1 Hot water throttle (where included in the delivery range).....	39
5.2 Dirt trap with/without fill and drain ball valve (depending on variant).....	40
5.3 Zone valve for heating circuit.....	41
5.4 Differential pressure regulator (depending on variant)	43
5.5 Thermostatic circulation bridge (depending on variant)	44
5.6 Return temperature limiter (add-on element).....	45
5.7 Thermostatic hot water mixing valve (add-on element)	45
5.8 Domestic water circulation system (LC 600/600+ add-on element)	47
5.10 Additional connection for static heating circuit (LC 600+, add-on element MM28).....	63
5.11 Claddings / covers for LC stations (as optional accessories)	64
5.12 Configuration examples	69
6. Commissioning.....	71
6.1 Flushing and filling.....	71
6.2 Initial start-up	71
6.3 Seized Grundfos pumps, type UPM3	72

7. Maintenance and service	74
7.1 Information regarding domestic water hardness	74
7.2 Maintenance checklist	75
8. Troubleshooting and remedying possible faults.....	77
9. Layout diagrams	77
10. Decommissioning, dismantling, disposal, environmental protection and disposal of electrical and electronic equipment	79

1. Safety instructions



Please follow these safety instructions carefully to prevent hazards and injury to persons and property.

These operating instructions are primarily designed for the safe use and installation of the device and make no claims to completeness.

These operating instructions describe the functionality of the device and are intended to provide information about the required safety instructions and to draw attention to possible hazards. Further technical information can be found in the other applicable documents.

These operating instructions are valid only for the described device and are not subject to the manufacturer's revision service. The sketches and drawings they contain are not suitable to scale.

- Keep the operating instructions within easy reach of all employees instructed to carry out work on the device so that they can refer to them as required.
- Keep the operating instructions in a clean, complete and legible condition throughout the entire period of use.
- Read the operating instructions before working on the device for the first time and consult them whenever uncertainties or doubts arise as to how the device should be handled.
- Should you come across any discrepancies when reading these operating instructions or should anything remain unclear, please contact the manufacturer.

Target group

These instructions are intended exclusively for authorised trained experts.

Only trained experts/installers authorised by the respective competence authority are permitted to work on heating systems, domestic water, gas and electrical circuits.

Regulations

When carrying out work, you must comply with:

- The legal regulations concerning accident prevention and legal regulations regarding environmental protection.
- The German Employer's Liability Insurance Association regulations,
- The pertinent safety requirements of DIN, EN, DVGW, TRGI, TRF and VDE,
- ÖNORM, EN, ÖVGW-TR Gas, ÖVGW-TRF and ÖVE,
- SEV, SUVA, SVGW, SVTI, SWKI and VKF
- and all current region- or country-specific regulations and standards

Instructions for working on the system

- Disconnect the system from the mains and monitor it to ensure that no voltage is being supplied (e.g. at the separate cut-out or a main switch).
- Secure the system from restarting / switching to auxiliary power supply.
- **WARNING!** Risk of scalding at media temperatures: >60°C

Note: In the case of anticipated high primary temperatures of >60°C, thermostatic scalding protection must be ensured at the domestic hot water draw-off point in order to restrict the outlet temperature (in the event of a power failure).

Permissible mains supply and operating parameters

Heating side/primary side:	Permissible pressure rating:	PN10
	Max. permissible operating temperature:	110°C
	Max. permissible differential pressure:	2.0 bar
	- With actuator for zone valve:	1.0 bar
Sanitation side:	Permissible pressure rating:	PN10
	Max. permissible operating temperature:	110°C
	- In the case of an existing sanitary circulation system:	65°C
	(for short periods max. 70°C < 2 h)	
	Min. cold water pressure:	1.5 bar
	Recommended cold water operating pressure:	2 bar
Max. permissible ambient temperature:		40°C

- The devices must be installed in enclosed, frost-free spaces
- Any noise emissions or radiant heat from the station must be taken into account in the choice of installation site
- Observe the safety areas in accordance with EN 60529 when designing and installing the system (equipment protection code in accordance with EN 60520 IP42)
- Any domestic hot water (DHW) installation must be made safe in compliance with DIN 1988 or DIN EN 806, for example, i.e. with the use of a safety valve and, where applicable, an expansion vessel.

1.1 Intended use

1.1.1 Proper use

Interface stations are used to transfer heat between the supply network and the heat consumer. Interface stations may only be used for this purpose in compliance with the maintenance and operating instructions and all relevant standards and regulations. All instructions in the operating instructions must be followed and the maintenance schedule adhered to.

Any deviation from the intended use may cause unintended hazards and is fundamentally not permitted.

The LogoComfort heat interface station provides a residential unit with space heating and domestic hot water according to the continuous flow principle. Any additional or alternative use is not permitted and regarded as an unintended use.

Appropriate use in heating and domestic water systems must be in accordance with the applicable DIN and local standards. Installing and operating the assembly incorrectly will invalidate any warranty claims. The shut-off valves may only be closed by an approved specialist when servicing, otherwise the safety valves will not work.

The LogoComfort heat interface station is not suitable for installation in adjacent recreation rooms or bedrooms.

Care must be taken to avoid sound transmission to adjacent walls or rooms!



Caution:

Do not make any changes to the electrical components, the design of the equipment or the hydraulic components! This would adversely impact on the safe function of the equipment.

Instructions concerning the place of use:

Before using our products, they must be checked regarding their suitability for the respective application.

In particular for heating systems, please take into account the properties of the heating water in accordance with VDI 2035 to protect the heating system and, for domestic water applications, the water quality at the place of use.

In the case of critical water qualities, please take action where necessary (e.g. water treatment) to prevent functional impairment and/or damage, e.g. corrosion damage.

In particular, please check the permissible limit values, e.g. electrical conductivity, the pH value, the water hardness level and the ammonium concentration.

Furthermore, in Germany all applicable norms, regulations and guidelines specific to the federal states must be taken into consideration, alongside the instructions in the applicable installation and operating manuals.

Further information can be found in the download section of www.flamcogroup.com.

1.1.2 Improper use

Using the device in any way that does not correspond to the intended use may be hazardous and is therefore prohibited.

In particular, the following is not allowed:

- The use of liquids other than water with the described properties
- Use of the device without prior knowledge of the operating instructions
- Use of the device without legible warning and information signs
- Use of the device in a faulty condition

1.2 Device designations

Designation:	Logotherm interface stations
Function:	Transfer of thermal energy to the heating supply and hot water preparation
Type:	LogoComfort
Manufacturer:	Meibes System-Technik GmbH

1.3 Hazard notes



The safety and warning information draws attention to residual hazards that cannot be avoided due to the design and construction of the device. Please always observe the measures shown for avoiding these hazards

Never alter or modify the station yourself. Such work may only be carried out by **qualified, specialist personnel**. This also applies to the electrical installation.

When the system is in operation, water-regulating components will be hot. Touching these system components can lead to scalding. The interface station and its heat-carrying components must be operated with permanent insulation. This insulation not only prevents unnecessary thermal dissipation, but also protects against accidental contact and burns. The insulation must therefore only be removed for maintenance or repair purposes and replaced correctly on completion of such work.

The system is operated using hot, high-pressure water, which can cause scalding on contact. You should therefore open the bleed or drain valves carefully and not work on pressurised parts.

The control components (controller, servomotors, pumps, etc.) are powered by mains voltage.

Therefore, always ensure the station is disconnected from the mains electrical supply when carrying out any maintenance or repair work. Secure the system against unauthorised operation.

Life-threatening electric shocks can be caused by spraying or splashing water. Escaping water may also disable the safety devices.

Any changes made to the station that have not been authorised by the manufacturer will invalidate any warranty claims.

Residual hazards:

The product has been built in accordance with the most relevant and recognised safety regulations. The following residual hazards may arise during installation, commissioning, maintenance and disassembly:

Warning: Risk of scalding from high media temperature

- Work with particular caution.
- Use personal protective equipment PPE (e.g. heat-resistant protective gloves).
- If necessary, the surface temperature must be measured before commencing any work.
- Use only designated and appropriate tools.

Hazard: Risk of injury from electrical voltage

- Only trained and qualified electricians may undertake work on electrical equipment.
- Electrical installation spaces must always be kept locked.

Warning: Risk of cuts and scratches due to the possibility of sharp edges

- Work with particular caution.
- Use personal protective equipment PPE (e.g. protective gloves).

Warning: there is a risk of impact/crushing if the station falls over

- Wear personal protective equipment PPE (such as protective work shoes).

1.4 What to do in the event of a breakdown or leaks

- Close any media lines using the appropriate valve.
- Contact a suitably trained expert or the customer service department of the manufacturer.

The device will only be cleared for operation again when the trained engineer has remedied the fault and restored the device to its intended condition.

1.5 Spare and wear parts

All spare parts to be used, must correspond to the technical requirements defined by Meibes System-Technik GmbH. This is guaranteed only by using genuine spare parts. The manufacturer is not liable for damage caused by the use of unapproved spare parts or ancillary materials.

Appropriate spare parts can be found in our documentation.

1.6 Requirements on trained engineers

A qualified professional must have undergone advanced technical training and have sufficient experience to independently perform complicated tasks or work associated with residual hazards. Each experience refers to a certain speciality, e.g. Maintenance, Electrical and/or HVAC Technician. In preparation for impending work, a qualified professional must be able to correctly estimate the feasibility, risks and hazards of the work as well as the equipment required. A qualified professional is expected to understand complex plans and descriptions of minimum preparation, and to obtain missing and required detailed information by suitable means.

The qualified professional must be able to restore and verify the intended/original state of the system. A worker can be a trained expert in several fields. For the performance of electrical works, only trained electricians according to DGUV regulation 3 may be used.

1.7 Liability and copyrights

We reserve all copyrights to this document. Any misuse, in particular reproduction or disclosure to third parties, is prohibited.

This original operating manual may not be reproduced or distributed, either in part or in its entirety, without the express permission of the manufacturer. This also applies to translations of this document and storage on other media. This document must not be used outside its intended purpose.

These installation and operating instructions must be given to the customer. The technician carrying out and/or authorising the work (e.g. installer) must explain the function and operation of the system to the customer in a comprehensible way.

1.8 Earth bonding or protective earthing in accordance with VDE



A terminal for earth bonding is provided on all heat interface stations. An appropriately labelled earth stud can be found on the base plate for this purpose

The cable's connection cross-section must be designed according to the applicable standards and regulations.

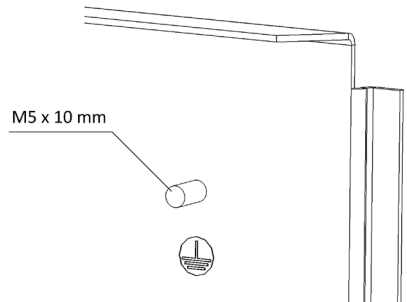

2. Functional description

The LogoComfort (LC) interface stations provide a residential unit with domestic hot water and heating. The domestic water is heated according to the continuous flow principle by a plate heat exchanger and a pressure-controlled proportional flow controller (PF controller with 3- way function) with anti-scale coating and DVGW (German Association for Gas and Water) approval.

Operation:

The PF controller with 3- way function only opens the domestic water and heating water media flows via the plate heat exchanger when the hot water is being drawn off. Once the water has been drawn off, the valve closes and thus prevents the continued heating of the heat exchanger. The dwelling heating circuit is shut off while the hot water is being drawn off (priority switching).

The entire thermal energy is thus available for the hot water preparation.

Notes:

If a constant heating supply temperature is ensured, the same hot water temperature is always achieved by means of proportional flow regulation when small or large quantities are drawn off.

The use of a thermal mixing valve* ensures scalding protection with very high or erratic heating medium temperatures and anticipated hot water temperatures of > 60°C.

We recommend using a thermostatic circulation bridge* at the end of the supply line or in the last station in order to guarantee the thermal stability and/or avoid waiting times until the desired hot water temperature is achieved.

If the connecting pipework between the supply line and the station is very long, it is worth installing a thermostatic circulation bridge* in every station. The differential pressure regulator* upstream of the station provides a stable pressure differential for the hot water preparation. Alternatively, it is possible to install the differential pressure regulator or another suitable fitting in the supply line (heating).

A zone valve permits hydraulic balancing of the dwelling heating circuit.

Installing a living space or reference room controller* allows independent operation of the dwelling heating circuit.

Any adapters* (L = 110 mm, 2 x ¾" MT) for optional water meters and heat meters allow retrofitting in the stations

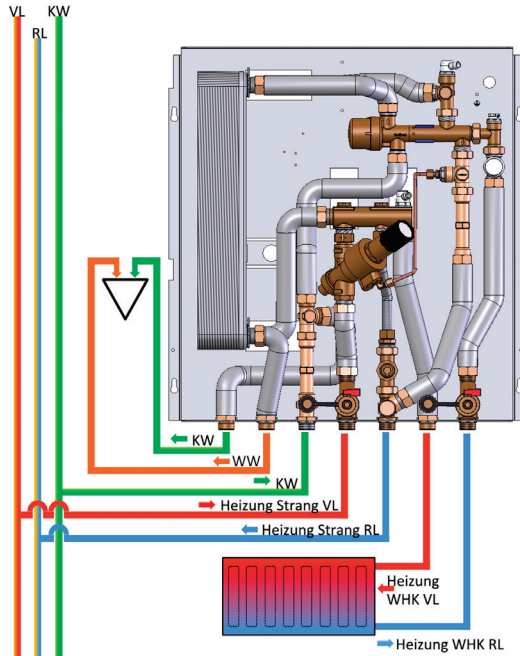

* Corresponding station components may be available or present as optional accessories or as add-on elements.

3. LogoComfort stations

The following sections describe the station variations as well as possible optional models with example illustrations.

3.1 LogoComfort 500/ 600 and 600+ as base stations

LogoComfort base station as a local interface station:

- for customisation
- incl. PF controller with priority switching, incl. adapters for optional heat meter
- Connection pipework made of insulated stainless steel corrugated tube, fully mounted on base plate and tested

The following base stations can be equipped with various add-on elements (see module summary, Section 3.1.4). These are installed in the factory and delivered as a prefabricated station. Corresponding surface-mounted / flush-mounted covers, as well as room controllers and accessories, are also available.

3.1.1 Technical data

LogoComfort base station variations with art. No.

Output**		LC 500 base	LC 600 base	LC 600+ base
35 kW	S-Line	M11401	M11301	M11304
46 kW	M-Line		M11303	M11306
Dimensions of WxHxD in mm (where depths depend on the optional accessories)		LC 500 base: 480 x 635 x 175 LC 600 base: 576 x 635 x 175 LC 600+ base: 480 x 657 x 175		
Heating capacity		10 kW (at 20 K)		
Hot water output**		35 kW (at 40 K), 12 l/min 46 kW (at 40 K), 17 l/min		

** Where FL=65°C and DW heating by 40 K

3.1.2 Design and components

	Components and connections	Hydraulic diagrams
LogoComfort 500/ 600 base	<p>Fig.: Example representations</p>	<p>Shown with possible add-on elements</p>
LogoComfort 600+ base	<p>Fig.: Example representations</p>	<p>Shown with possible add-on elements</p>

Key for LogoComfort base stations

No.	Components	Comment
1	Stainless steel plate heat exchanger	
2a	Adapter for cold water meter (L = 110 mm, 2 x ¾" MT)	Option
2b	Adapter for heat meter (L = 110 mm, 2 x ¾" MT)	
3	Stainless steel corrugated tube pipework, insulated	
4a	Dirt trap with flushing, filling and drain ball valve	Option
5	Differential pressure regulator, control range 10-40 kPa	Option
6	PF controller with 3- way function	with priority switching, anti-calcification coating and DVGW approval
7	2nd CW connection	Option
8	Thermostatic circulation bridge 35 ... 65°C	Option
9	Zone valve (optional: living space controller), for 1st HC included delivery range	Control valve for heating water (dwelling)/ zone valve
13	Hot water throttle 12 or 17 l/min	
14	Automatic air vent	Bleed valve on the heating side
15	Thermostatic hot water mixer (scald protection)	Option
17	Return line temperature limiter 45... 65°C	Option
18	½" coupler for heat meter immersion sleeve	Option , if Item 20 present
19.1	Domestic water circulation group, only for 600/600+	Option
19.2	Circulation bridge 35 ... 65°C, only for 600/600+	Option , if Item 19.1 present
20	DN20 shut-off valve, union nut x ¾" FT domestic water ball valve DVGW approved, FL ball valve with HFM sensor	Option
21	Corresponding mixing circuit with HE pump	Depending on the variant

Connections

A	Cold water outlet for dwelling, (second CW connection) - <i>Option</i>	G ¾" MT (without ball valves)
B	Domestic hot water outlet for dwelling (HW)	
C	Cold water inlet building connection (CW)	
D	Heating – flow line building connection (FL heating)	
E	Heating – return line building connection (RL heating)	
F	Heating – flow line dwelling heating circuit 1 (unmixed or mixed HC) - depending on the variant	
G	Heating – return line dwelling heating circuit 1 (unmixed or mixed HC) - depending on the variant	
H	Heating – flow line dwelling heating circuit 2 (unmixed HC) - <i>option</i>	
I	Heating – return line dwelling heating circuit 2 (unmixed HC) - <i>option</i>	
J	Domestic water circulation - <i>option</i>	

Note: for optional components, see Section 3.1.4

3.1.3 Dimensions of connections and base plate with keyholes

Note: Dimensions relate to stations without housing or covers!

<p>LogoComfort 500/600 base</p>		<p>Dimensions in [mm]</p> <p>a=480 (576) b=620 c=110 d=65 e=24.5 (72.5) f=50 g=462 (558) h=450 i=68</p> <p>Warning! For 600 series stations, dimensions are given in brackets (xxx)</p>
<p>LogoComfort 600+ base</p>		<p>Dimensions in [mm]</p> <p>a=576 b=620 c=110 d=65 e=58.8 f=50 g=558 h=450 i=68</p>

Fig.: Example representations

3.1.4 Add-on elements LogoComfort 500/600 and 600+ as base stations

The following add-on elements (modules) may be present. These are installed at the factory. The possible combination options are also included in the current price list.

3.1.4.1 Summary of add-on elements and LC equipment options

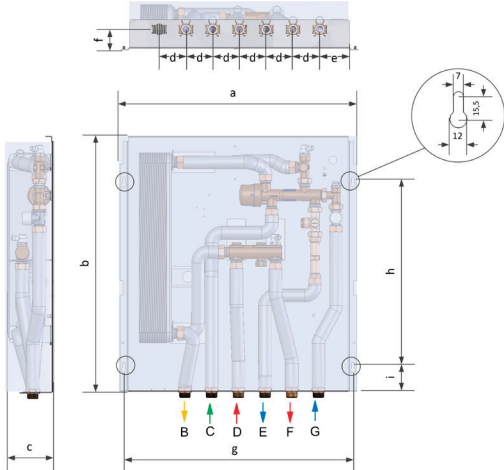
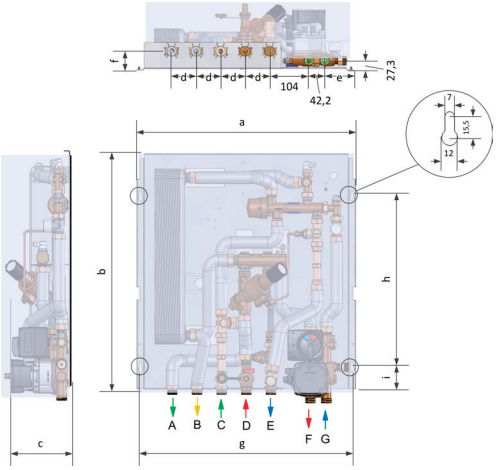
Module for LC base stations

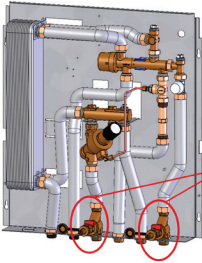
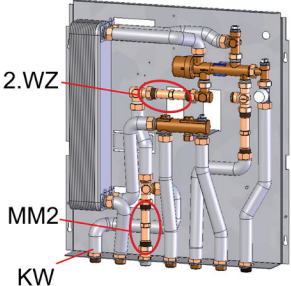
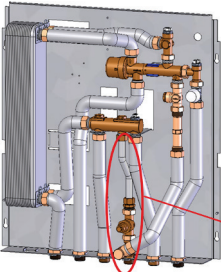
500	600	600+	Components	Fig. Modules (example representations)	See section
	MM1	-	2x dirt traps with drainage Note: For LC 600 base variants with side connection sets as a mixing circuit or for the LC 600+, only 1 x dirt trap is possible in each case (see MM26 module)	 MM1	5.2
	MM2		Cold water connection (CW) with CW meter connection piece	 2.WZ MM2 KW	4.5.2
	Art. No.: M10253.8		2nd water meter adapter (2nd WM) for stations with MM2 module		
	Art. No.: M10253.7		2nd water meter adapter (2nd WM) for stations without MM2 module		
	MM4		Adjustable circulation bridge 35-65°C	 MM4	5.5

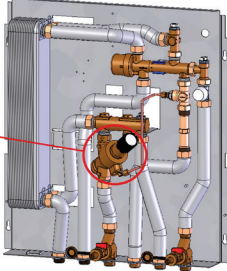
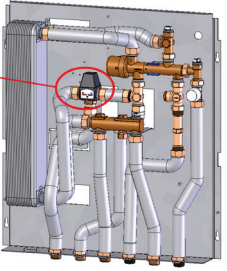

MM5	Differential pressure regulator with control range 10-40 kPa		5.4
MM6	Scalding protection: thermostatic hot water mixer valve, adjustable: 35-60°C		5.7

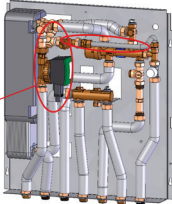
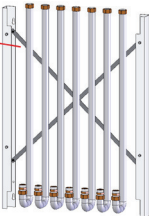
Module for LC base stations

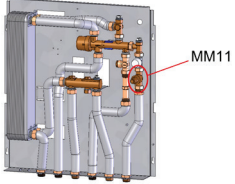
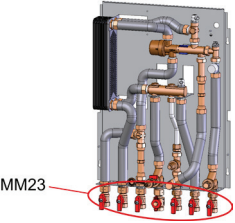
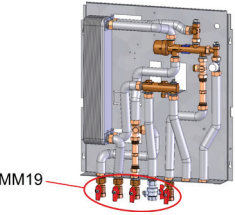
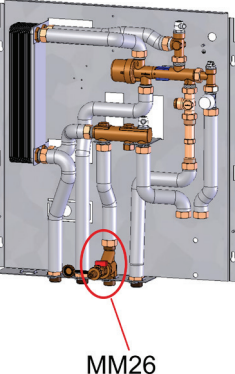
500	600	600+	Components	Fig. Modules (example representations)	See section
-		MM8 (Art No.: M10252.12)	Domestic water circulation with: - Pump incl. automatic timer - Backflow preventer - Adjustable circulation bridge 35-65°C		5.8
MM9	-		Top connection with: 7 x connection lines, frame depth 50 mm		4.4

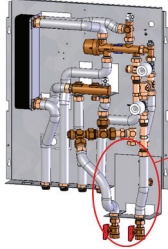
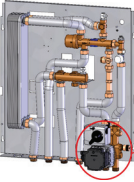
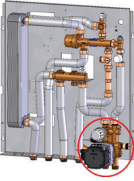
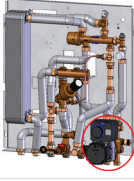
MM11		Return line temperature limiter 35-65°C		5.6
MM23 (Art No.: M10252.32)	-	Straight-way ball valve set with: 7x DN20 BV, flow line ball valve for HFM sensor mounting Note: Domestic water ball valve DVGW-approved		4.3
MM19 (Art No.: M10252.34)		Straight-way ball valve set with: 5x DN20 BV, flow line ball valve for HFM sensor mounting Note: Domestic water ball valve DVGW-approved		
-	MM26	1x dirt trap with drainage Note: for LC 600 base variants with side connection set as a mixing circuit or for LC 600+		5.2

-		MM28	Additional connection for static heating circuit Note: only up to manifolds for 5 HC, from the 6th HC only in combination with 600 base		MM28	5.9.4.2.
-	-	MM12HE	Compact mixing circuit group with servomotor and HE pump for UFH manifold 3-8 HC (type B).		MM12HE	5.9
-	-	MM13HE	Compact mixing circuit group with thermostatically controlled mixing circuit and HE pump for UFH manifold 3-8 HC (type B)		MM13HE	
-	-	MM27HE	Compact mixing circuit group with controlled servomotor, flow line temperature sensor and HE pump for UFH manifold 3-8 HC (type B)		MM27HE	
-	√	-	Corresponding side connection sets as a mixing circuit with HE pump for optional manifold 3-12 HC (type E)			
-	Type E	Type B	Underfloor heating circuit manifold, type B: 3-8 or type E: 3-12 HC			
		MB-10560.09	Pre-wiring concept for use with up to 8 zones*			
		MB-10560.10	Pre-wiring concept for use with up to 10 zones*			
* Up to 18 actuators can be connected and therefore multiples in each zone						
MM10230.5SC	-	MM10230.5SC	Heat exchanger for domestic water with high conductivity for 12 l/min			
-		MM10232.58ES	Heat exchanger for domestic water with high conductivity for 17 l/min			
-		M10230.51	Insulated HE for 12 l/min			
-		M10232.592	Insulated HE for 17 l/min			

M4325.1227.50	Meiflex SST flushing hose ¾" FT x FT, 500 mm long		4.2.2
M43.66124D	Flushing connections 10x DN16 double nipples (¾" flat-sealing)		

3.1.4.2 Combination options of the add-on elements for LC 500/600 and 600+

LC 500 base stations	MM2 Cold water connection	MM4 Circulation bridge	MM5 Differential pressure regulator	MM6 Scalding protection	MM9 Top connector set	MM11 Return line temperature limiter	MM23 Straight-way ball valve set DN20
Combination options of the individual add-on elements (modules)							
Dirt trap with drainage MM1	o	o	o	o	o	o	o
Cold water connection MM2		o	o	o	o	o	o
Circulation bridge MM4			o	o	o	o	o
Differential pressure regulator MM5				o	o	o	o
Scalding protection MM6					o	o	o
Connector set top MM9						o	o
Return line temperature limiter MM11							o

Key: o = possible

LC 600 base stations	MM2 Cold water connection	MM4 Circulation bridge	MM5 Differential pressure regulator	MM6 Scalding protection	MM8 domestic water circulation with pump	MM9 Top connector set	MM11 Return line temperature limiter	Heating circuit manifold	MM23 Straight-way ball valve set DN20
Combination options of the individual add-on elements (modules)									
Dirt trap with drainage MM1	o	o	o	o	o	o	o	o	o
Cold water connection MM2		o	o	o	o	o	o	o	o
Circulation bridge MM4			o	o	x	o	o	o	o
Differential pressure regulator MM5				o	o	o	o	o	o
Scalding protection MM6					o	o	o	o	o
Domestic water circ. with pump MM8						x	o	o	o
Connector set top MM9							o	x	o
Return line temperature limiter MM11								o	o
Heating circuit manifold									o

Key: o = possible, x = not possible

Note on the LC 600 base:

Manifold installed on base plate for possible connection sets with heating circuit pump: see Section 5.9.2

LC 600+ base stations

Combination options of the individual add-on elements (modules)

	M13HE Thermostatic mixing circuit	M27HE Mixing circuit with controlled servomotor and FL temperature sensor	MM26 Dirt trap with drainage	MM2 Cold water connection	MM4 Circulation bridge	MM5 Differential pressure regulator	MM6 Scalding protection	MM8 domestic water circulation with pump	MM11 Return line temperature limiter	Heating circuit manifold	MM28 Additional connection for static HC
Mixing circuit with servomotor MM12HE	x	x	o	o	o	o	o	o	o	o	o
Thermostatic mixing circuit MM13HE		x	o	x	o	o	o	o	o	o	o
Mixing circuit with controlled servomotor and FL temperature sensor MM27HE			o	o	o	o	o	o	o	o	o
Dirt trap with drainage MM26				o	o	o	o	o	o	o	o
Cold water connection MM2					o	o	o	o	o	o	o
Circulation bridge MM4						o	o	x	o	o	o
Differential pressure regulator MM5							o	o	o	o	o
Scalding protection MM6								o	o	o	o
Domestic water circulation with pump MM8									o	o	o
Return line temperature limiter MM11										o	o
Heating circuit manifold											o

Key: o = possible, x = not possible

3.2 LogoComfort 500/600 and 600+ as prefabricated stations

LogoComfort - prefabricated station as a local interface station:

- incl. adapters for optional hot and cold water meters
- incl. second CW connection for domestic connection and incl. differential pressure regulator for heating circuit
- Connection pipework made of insulated stainless steel corrugated tube
- Fully mounted on base plate and inspected
- For LC 600+ with mixing circuit for e.g. underfloor heating (with the LC 600, optionally as a side connection set)
- Further optional accessories, e.g.: 7 x DN20 straight ball valves (FL ball valve for sensor support for possible heat meters), note: with the LC 500 variant, 35 kW with BV, already included

3.2.1 Technical data

LogoComfort prefabricated station variants with Art. No.

Type LC	Output**		without circulation bridge	with adjustable circulation bridge
500	35 kW	S-Line	M11203.4	M11204.9
	35 kW with BV*	S-Line	M11203.1	M11204.1
600	46 kW	M-Line	-	M11104.21
600+	35 kW	S-Line	-	M11104.31
	46 kW	M-Line	-	M11104.33

* BV ball valves incl. (otherwise as optional accessories)

Dimensions of WxHxD in mm (where depths depend on the optional accessories)	LC 500: 480 x 635 x 175 LC 600: 576 x 635 x 175 LC 600+: 480 x 657 x 175
Heating capacity	10 kW (at 20 K)
Hot water output**	35 kW (at 40 K), 12 l/min 46 kW (at 40 K), 17 l/min

** Where FL=65°C and DW heating by 40 K

3.2.2 Design and components

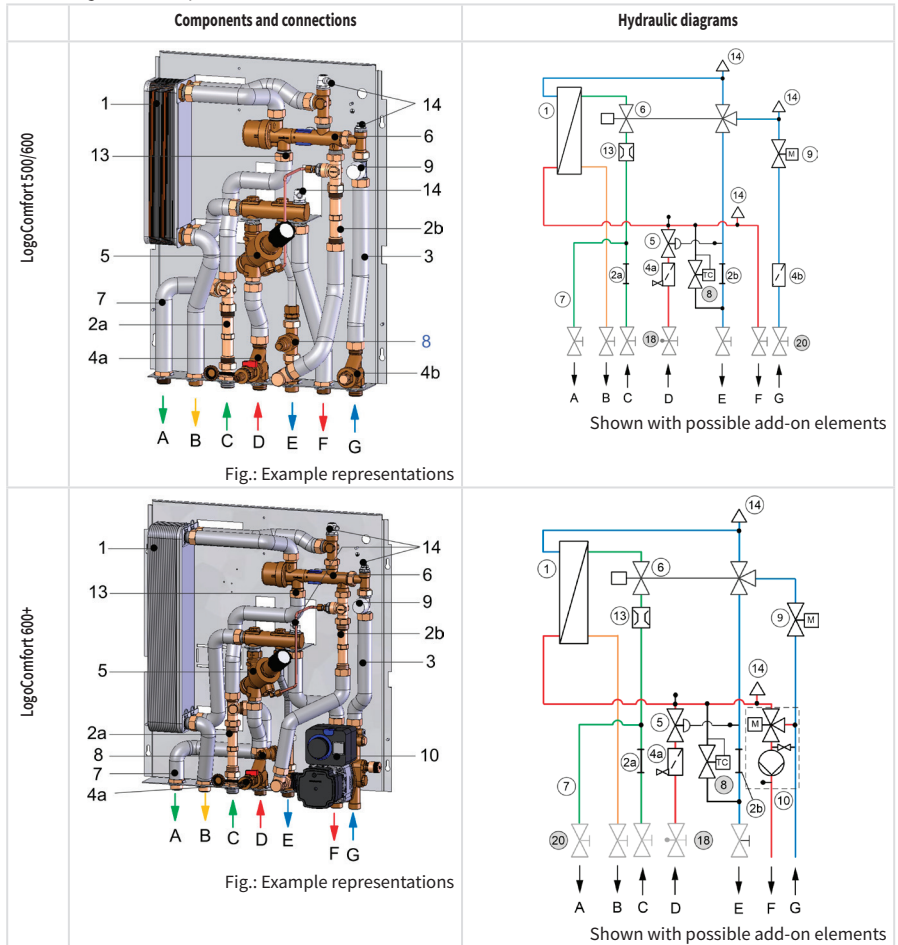

Key for LogoComfort prefabricated stations

No.	Components	Notes
1	Stainless steel plate heat exchanger	Copper-soldered
2a	Adapter for the cold water meter	L = 110 mm, 2 x 3/4" MT
2b	Adapter for the heat meter	L = 110 mm, 2 x 3/4" MT
3	Stainless steel corrugated tube	With insulation
4a	Dirt trap with flushing, filling and drain ball valve	
4b	Dirt trap including 3/8" FT connector with stopper, closed	Not for 600+
5	Differential pressure regulator	Control range 10-40 kPa

6	PF controller with 3- way function	with priority switching, anti-calcification coating and DVGW approval
7	2nd KW connection	
8	Thermostatic circulation bridge 35 ... 65°C	depending on the variant
9	Zone valve (optional: living space controller)	Control valve for heating water (dwelling)/zone valve
10	Compact mixing circuit group with HE pump (UPM3 Auto 17-70) and controlled servomotor plus FL sensor	Only for 600+ Also see descriptions for the MM27HE module, from Section 5.9.3
13	Hot water throttle	12 or 17 l/min
14	Automatic air vent	Bleed valve on the heating side
18	Coupler 1/2" for heat meter immersion sleeve	if Item 20 present
20	DN20 shut-off valve, union nut x 3/4" FT domestic water ball valve DVGW approved, FL ball valve with HFM sensor	depending on variant or optional

Connections

A	Cold water outlet for dwelling, (second CW connection)	G 3/4" MT (without ball valves)
B	Domestic hot water outlet for dwelling (HW)	
C	Cold water inlet building connection (CW)	
D	Heating - flow line building connection (FL heating)	
E	Heating - return line building connection (RL heating)	
F	Heating - flow line dwelling heating circuit (FL dwelling)	
G	Heating - return line dwelling heating circuit (RL dwelling)	

3.2.3 Dimensions of connections and base plate with keyholes

Note: Dimensions relate to stations without housing or covers!

<p>LogoComfort500/600</p>		<p>Dimensions in [mm]</p> <p>a=480 (576) b=620 c=175 d=65 e=24.5 (72.5) f=50 g=462 (558) h=450 i=68</p> <p>Warning! For 600 series stations, dimensions are given in brackets (xxx)</p>
<p>LogoComfort600+</p>		<p>Dimensions in [mm]</p> <p>a=576 b=620 c=175 d=65 e=58.8 f=50 g=558 h=450 i=68</p>

Fig.: Example representations

3.2.4 Accessories

Overview:

for LogoComfort prefabricated stations		500	600	600+	See Section
Mounting rail, assembly aids	Corner, surface-mounted / flush-mounted	-	-	M10203.161	4.2
	Flush-mounted connection	-	M10203.12		
Domestic water circulation (pre-installed at the factory) incl. time control option		-	MM8		5.8
M13HE connection sets (thermostatically controlled mixing circuit with HE pump)	3-12 heating circuits	-	M10512.27	-	5.9
M27HE connection sets (mixing circuit with controlled servomotor and HE pump)	3-12 heating circuits	-	M10512.28	-	
M12HE connection sets (mixing circuit with servomotor* and HE pump)	3-12 heating circuits	-	M10512.29	-	
Pre-wiring concept for use with up to 8 zones (Up to 18 actuators can be connected and therefore multiples in each zone)		-	MB-10560.09		
Pre-wiring concept for use with up to 10 zones (Up to 18 actuators can be connected and therefore multiples in each zone)		-	MB-10560.10		
Additional connection for static heating heating (only up to manifolds for 7 heating circuits, from the 8th HC only in combination with 600 base)		-	-	MM28	5.9.4.2
Heat exchanger for domestic water with high conductivity	at 12 l/min	MM10230.5SC	-	MM10230.5SC	
	at 17 l/min	-	MM10232.58ES		

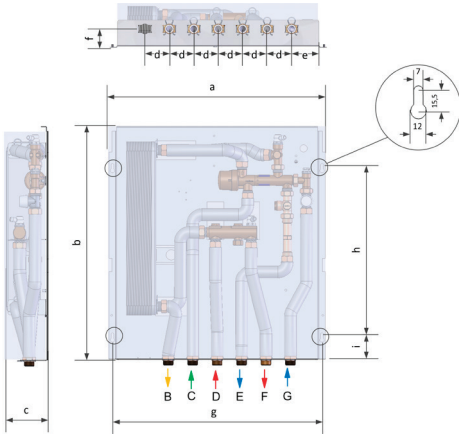
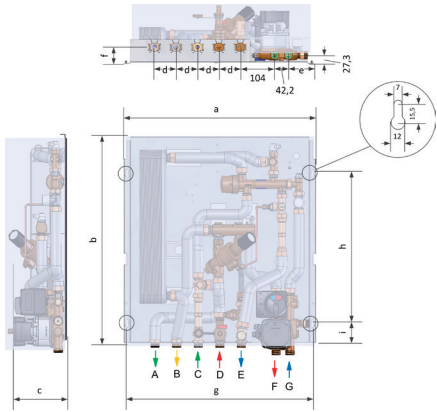
* An external controller is required to control the mixing circuit

Notes:

Matching surface-mounted and flush-mounted cladding	See Section 5 or see current price list
Heating circuit manifold, ball valves	
Controller and actuator for UFH valve	
Complete control sets (living space control device and actuator)	

3.3 LogoComfort complete stations (CS)

The LogoComfort 600 and 600+ complete stations are ready-to-fit, decentralised interface stations with PF-controlled hot water preparation and heating supply as a system for wall mounting, including housing.

The delivery range also includes:

- Zone valve, adapters (3/4" x 110 mm) for optional hot and cold water meters, dirt traps with drainage function, second dwelling CW connection, adjustable circulation bridge (35-65°C), differential pressure regulator (10-40 kPa) and DN 20 ball valve set
- For MK variants, a controlled servomotor, FL temperature sensor and HE pump
- Insulated stainless steel pipework; all components are fully mounted on a base plate and inspected
- Pre-wiring concepts (MB-10560.01/02) are possible as accessories, see Section 5.9.4

Overview of variants:

LC KS	MC Mixing circuit for UFH manifold	RH Static HC	Surface-mounted (SM) Art. No.	Flush-mounted (FM) Art. No.
600	-	1x	M11104HKAP/ -ES	M11104HKUP/ -ES
600+	Up to 6 HC	-	M11104.6MKAP/ -ES	M11104.6MKUP/ -ES
600	Up to 9 HC	1x	M11104.9MKAP/ -ES	M11104.9MKUP/ -ES

Each possible as a variant with copper (CU) / stainless steel (SS) welded plate heat exchanger

Bottom connection (ball valves)	3/4" FT
Heating capacity	10 kW (at 20 K)
Hot water output**	46 kW (at 40 K), 17 l/min (M-Line)

** Where FL=65°C and DW heating by 40 K

Example representations:

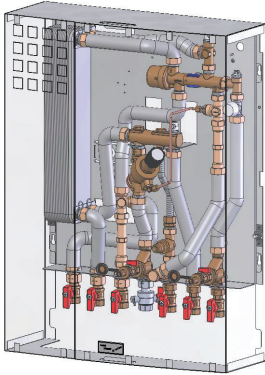
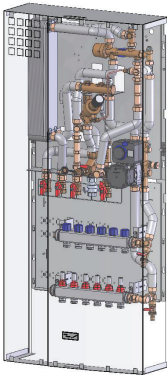
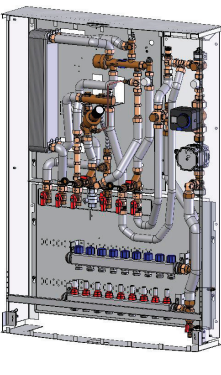
	LC 600 KS	LC 600+ KS up to 6 HC	LC 600 KS up to 9 HC
Surface-mounted models, dimensions WxHxD			
	600x800x210 mm	600x1330x210 mm	850x1210x210 mm

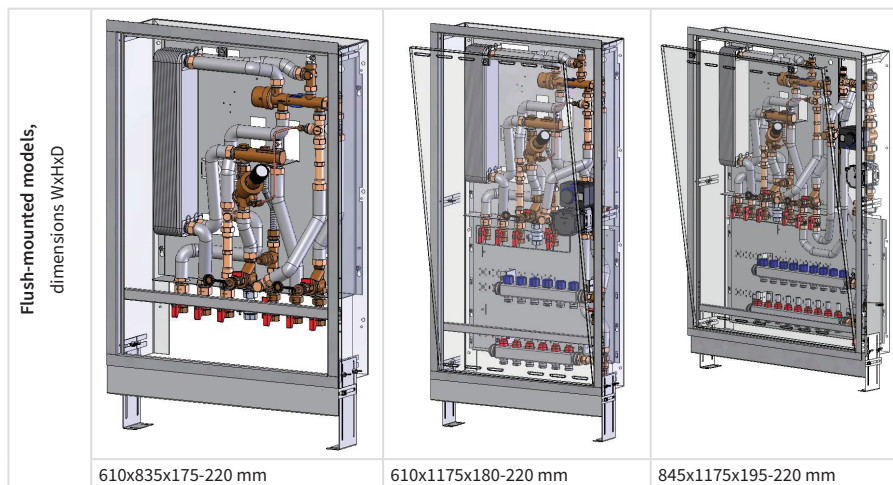

Notes on installation and descriptions of individual components: see next sections.

3.4 LogoComfort thermal heat exchanger (BE) 500/600 mm wide

LogoComfort - thermal heat exchanger station as a local interface station:

- incl. adapters for heat meters
- incl. differential pressure regulator
- Connection pipework made of insulated stainless steel corrugated tube
- Fully mounted on base plate and inspected
- as optional accessory, e.g.: 6 x DN straight ball valves (FL ball valve for sensor support for possible HFM)

3.4.1. Technical data

LogoComfort thermal heat exchanger variants with Art. No.

Type LC BE	Output**		without circulation bridge	with adjustable circulation bridge
500	35 kW	S-Line	M11201.3TAGB	M11202.3TAGB
600	46 kW	M-Line	M11201.4TAGB	M11202.4TAGB

Dimensions of WxHxD in mm (where depths depend on the optional accessories)	LC BE 500: 480 x 635 x 175 LC BE 600: 576 x 635 x 175
Heating capacity	10 kW (at 20 K)
Hot water output**	35 kW (at 40 K), 12 l/min 46 kW (at 40 K), 17 l/min

** Where FL=65°C and DW heating by 40 K

3.4.2. Design and components

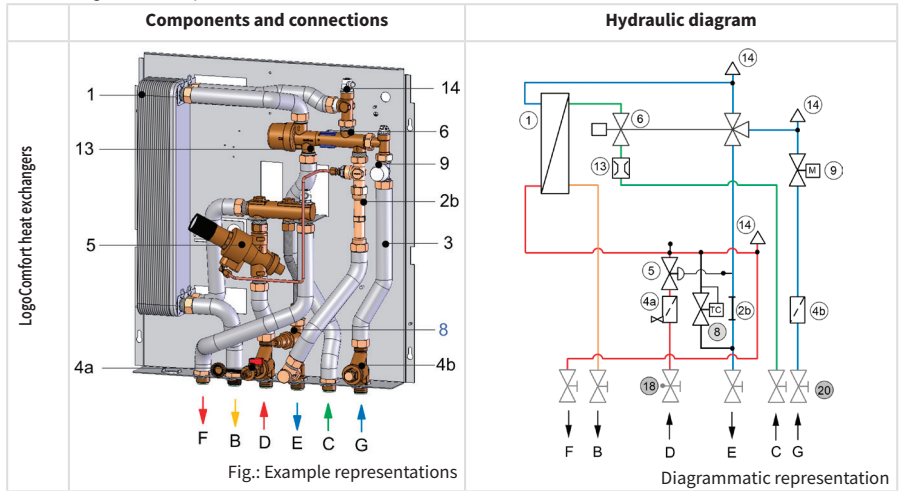

Key for LogoComfort thermal heat exchanger

No.	Components	Notes
1	Stainless steel plate heat exchanger	Copper-soldered
2b	Adapter for the heat meter	L = 110 mm, 2 x 3/4" MT
3	Stainless steel corrugated tube pipework	With insulation
4a	Dirt trap with flushing, filling and drain ball valve	
4b	Dirt trap including 3/8" FT connector with stopper, closed	
5	Differential pressure regulator	Control range 10-40 kPa
6	PF controller with 3- way function	with priority switching, anti-calcification coating and DVGW approval
8	Thermostatic circulation bridge 35 ... 65°C	depending on the variant
9	Zone valve (optional: living space controller)	Control valve for heating water (dwelling)/zone valve
13	Hot water throttle	12 or 17 l/min
14	Automatic air vent	Bleed valve on the heating side
18	1/2" coupler for heat meter immersion sleeve	if Item 20 present
20	DN20 shut-off ball valve, union nut x 3/4" FT, DVGW-approved domestic water ball valve, FL ball valve with HFM sensor	optional

Connections

B	Domestic hot water outlet for dwelling (HW)	G 3/4" MT
C	Cold water inlet building connection (CW)	
D	Heating - flow line building connection (FL heating)	
E	Heating - return line building connection (RL heating)	
F	Heating - flow line dwelling heating circuit (FL dwelling)	
G	Heating - return line dwelling heating circuit (RL dwelling)	

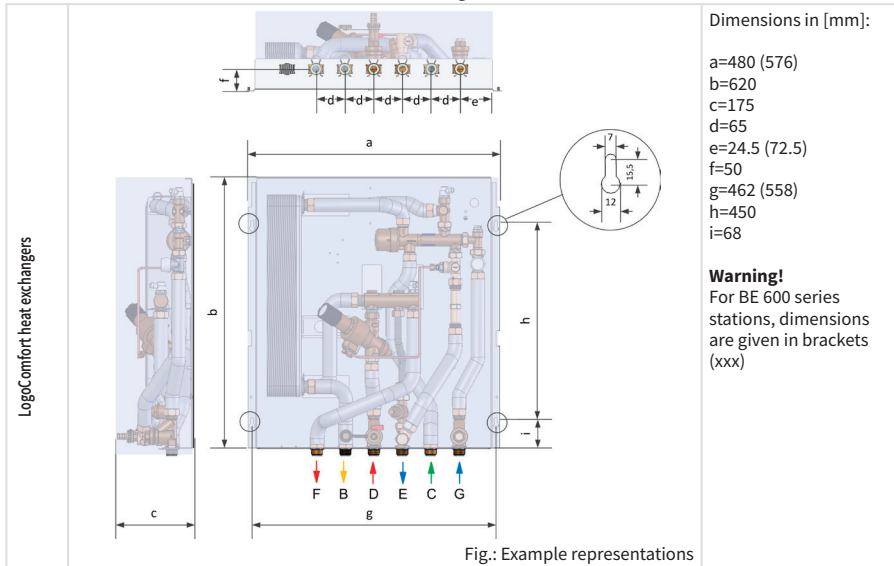

3.4.3. Dimensions of the connections and base plate and keyholes

Note: Dimensions relate to stations without housing or covers!



3.4.4. Accessories

for LogoComfort thermal heat exchangers	BE 500	BE 600	See Section
Heat exchanger for domestic water with high conductivity	MM10230.5SC	MM10232.58ES	
Ball valves, straight 6 x DN20	M10252.35		4.3
Surface-mounted cover long	M11200.1L	M11200.2L	5.11
Surface-mounted cover long, with plastic insert for radio use	M11200.1KL	M11200.2KL	
Salus HTRP230 room temperature controller	M10561.31		
Electro-thermal actuator	M10560.98-		
STM, underfloor heating circuit	M10560.94		

	LC BE connection sets:	Figures	Art. No.
Wall-mounted	<ul style="list-style-type: none"> - DN16 stainless steel corrugated tube, 2 m - FixLock double nipple (6x) - FixLock set of threaded joints (2x) 		MB-46123TAG
Flush-mounted	<ul style="list-style-type: none"> - DN16 stainless steel corrugated tube, 2 m - FixLock double nipple (6x) - FixLock set of threaded joints (2x) - Bracket R 1/2 FT/MT (2x) - Bracket R 3/4 FT/MT (2x) 		MB-46123.1TAG

Note

Corresponding control sets: see current price list

4. Installation

Please follow the safety instructions contained in this document and any additional assembly instructions during installation! Installing and operating the stations incorrectly will invalidate any warranty claims.

Station installation options:

- Wall-mounted: with surface-mounted cover (SMC)
 with flush-mounted cover (FMC)
- Floor-standing: with flush-mounted cover (FMC) and possibly with feet

Notes: if installing with flush-mounted cover, please refer to the following points!
(for LC 600/600+ stations, dimensions are given in brackets)

4.1 Installation notes using the example of the flush-mounted cover for LC 500/600 and 600+

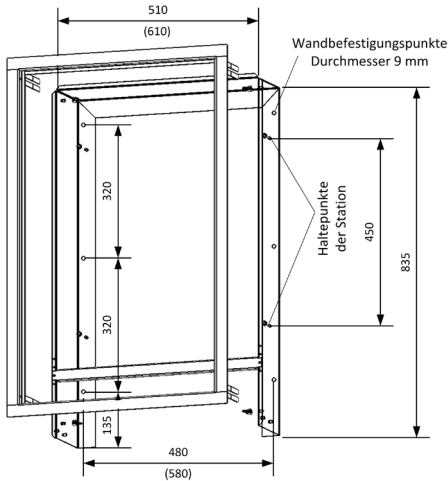

Example representation

- Possible installation depth: 150 to 220 mm

The min. installation depths in combination with FMC must be noted for the following modules:

Modules for LC 500, 600 and 600+		Min. construction depth
Differential pressure regulator	MM5	175 mm
Domestic water circulation	MM8	180 mm
Mixing circuit with HE pump	M12, M13, M27HE	195 mm
Additional unmixed heating circuit	MM28 (for LC 600+)	195 mm
with underfloor heating circuit manifold	(up to 8 or 12 HC)	180 mm
Where there is joint installation of the terminal strip and holder (10203.021 or .678)	Terminal strip 10560.961	199 mm
	Terminal strip 10560.962, .963, .964	187 mm

For more information on covers (SMC/FMC) and claddings, see Section 5.11

4.2 Mounting rails and assembly aids for surface and flush mounting (optional accessories)

4.2.1. Mounting rails incl. DN20 ball valves

Overview of LC mounting rails: Structure, dimensions and Art. No.

<p>For LC 500</p>		<p>M10203.160</p>
<p>For LC 600</p>		<p>M10203.158</p>
<p>For LC 600</p>		<p>M10203.161</p>

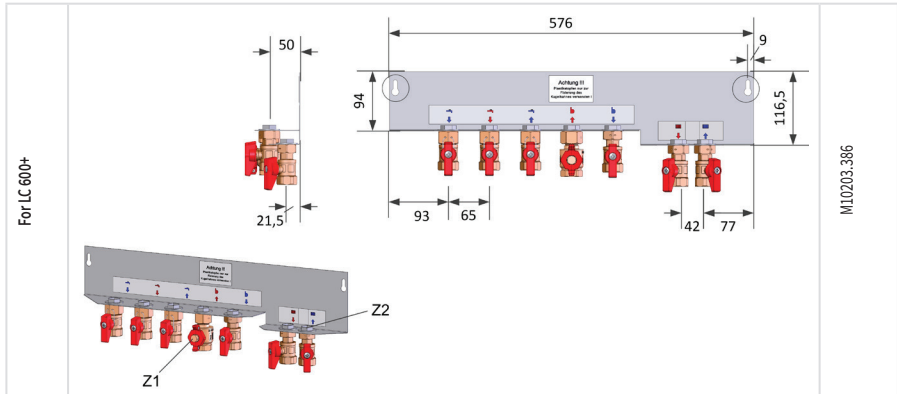

Notes:

- FL ball valve (Z1) with sensor Option to accommodate an optional HFM (only for straight BV)
- Please use plastic plugs (Z2) only to fix the ball valves!

4.2.2. Assembly aids

Overview

Description	Fig.	Art. No.
7 x DN20 straight ball valves with HFM sensor mounting, DW ball valves DVGW-approved		M10252.32 (e.g. MM23 for LC 500/600)
5 x DN20 straight ball valves with HFM sensor mounting, DW ball valves DVGW-approved		M10252.34 (e.g. MM19 for LC 500/600 and 600+)
6 x DN20 straight ball valves with HFM sensor mounting, DW ball valves DVGW-approved		M10252.35 (e.g. for LC BE 500/600 stations)
1 x reinforced tube FT x FT 3/4" x 500 mm as connection for the flushing process	<p>Example application:</p>	M4325.1227.50

10 x DN16 MS flat-sealing 3/4" double nipples		M43.66124D
---	---	------------

4.3 DN20 straight-way ball valves (add-on elements)

Overview 3/4" thread ball valves with union nut x FT and red BV handle, unmachined brass

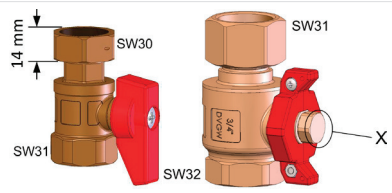
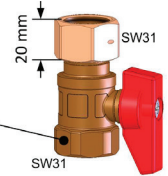
For heating (FL/RL)	 <p>(61801.2) (61881.24)</p>
For domestic water (CW/DHW)	<p>-gekennzeichnet mit DVGW / WRAS</p>  <p>(61801.22)</p>

Notes:

- Fit the corresponding ball valves tightly onto the matching station connections
- The respective torques must be observed during installation
- Ensure the correct use of media for the ball valves (for heating / domestic water)!

4.4 Top connections (add-on element)

Dimensions M9 module: Frame and connection line for LC 600 (or LC 500):

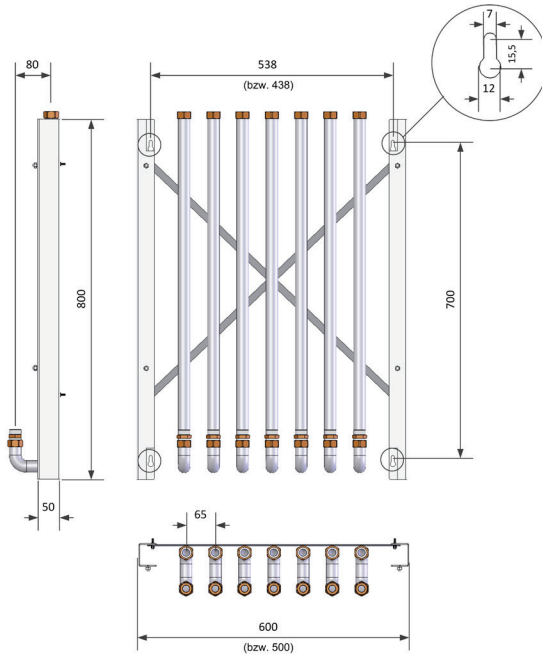

4.5 Installation of optional components (depending on variant)

Note:

The following figures are example illustrations and show the components installed in a LogoComfort 500 station.

4.5.1. Heat meter installation

The heat meter may only be installed once the entire heating system has been flushed through. LogoComfort stations are fitted with an adapter (L = 110 mm x 3/4") for a heat meter that must be removed before the heat meter is installed.

Recommendation: use of an ultrasonic heat meter from Flamco/Meibes

Procedure:

1. Close all shut-off valves "A" (if fitted, optional accessories) in the station.
2. Lower the system pressure by opening the bleeding devices "B".
3. Release the screw fittings on adapter "C".
 - **WARNING:** Water may leak from the system. (The station can be drained using the boiler fill and drain ball valves provided.)
4. Remove the adapter and insert the heat meter and screw in place.
 - **Note:** Bear in mind the direction of flow. (Do not forget the seals)
5. Remove the M10x1 plug "E" (if present) on the flow line ball valve, otherwise at position "D", and screw in and seal the heat meter flow line sensor.
6. Once the work is complete, re-open the shut-off valves and use the bleeding devices to bleed the station. Perform a leak-tightness check.

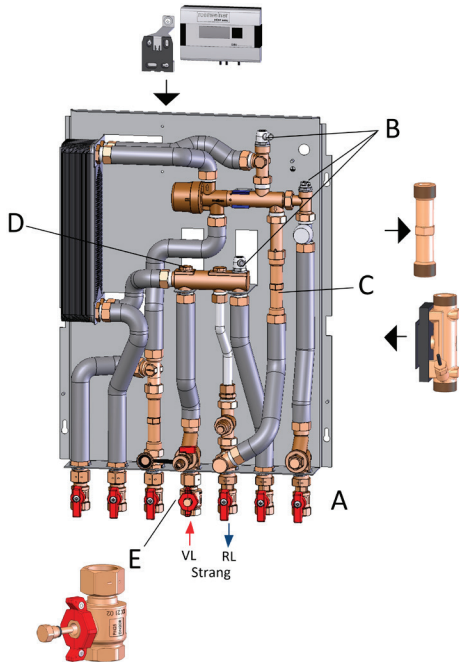

4.5.2. Cold water meter installation

LogoComfort stations are fitted with an adapter (L = 110 mm x 3/4") for a cold water meter that must be removed before the cold water meter is installed.

Procedure:

1. Close all shut-off valves "A" (if present) in the station.
2. Release the threaded joints on adapter "B". WARNING: Water may leak from the system.
3. Remove the adapter and insert the cold water meter and screw into place.
 - **Note:** Bear in mind the direction of flow. (Do not forget the seals)
4. Once the work is complete, re-open the shut-off valve and check the threaded joints for leaks.

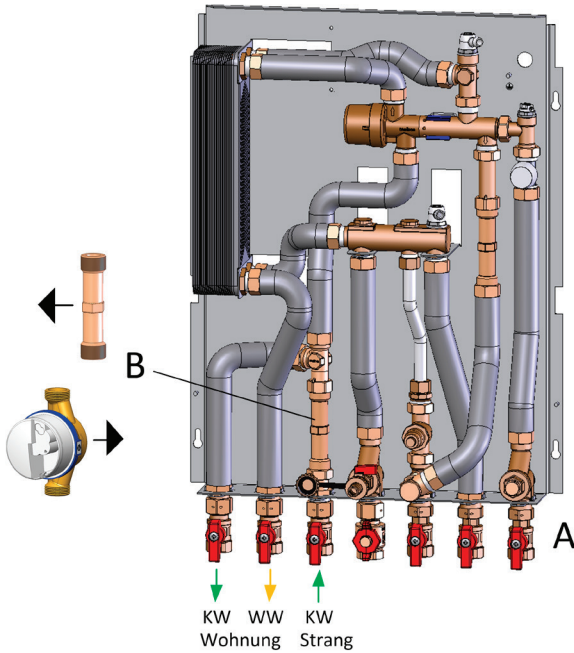

5. Description of individual components and setting options

Note:

The following figures are example illustrations and show the components installed in a LogoComfort 500 station.

5.1 Hot water throttle (where included in the delivery range)

LogoComfort stations are fitted with a hot water throttle "X" in the PF controller connecting pieces.

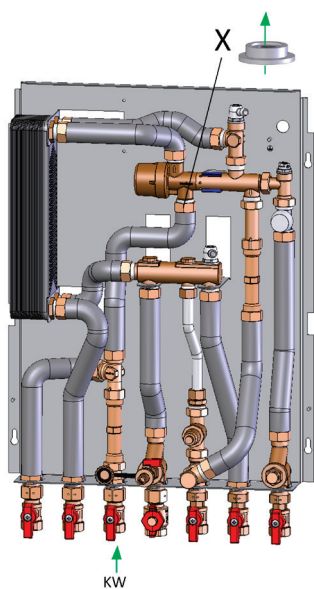

Thanks to the design of the PF controller with a sealing bushing made of PTFE (Art. No.: ME-10240.801), it can be replaced.

The following throttle plates or flow regulators can be flow rate used if required, e.g.:

Max. flow rate in l/min	Colour coding of the throttle plate	Art. No.
10	Blue	ME-10240.802
12	Red	ME-10240.803
15	Lime green	ME-10240.804
17	Brown	ME-10240.805

5.2 Dirt trap with/without fill and drain ball valve (depending on variant)

The dirt traps in the station's heating water inlets protect the system against sludge and impurities. These can be flushed through by opening the fill and drain ball valve fitted. The station must be depressurised beforehand.

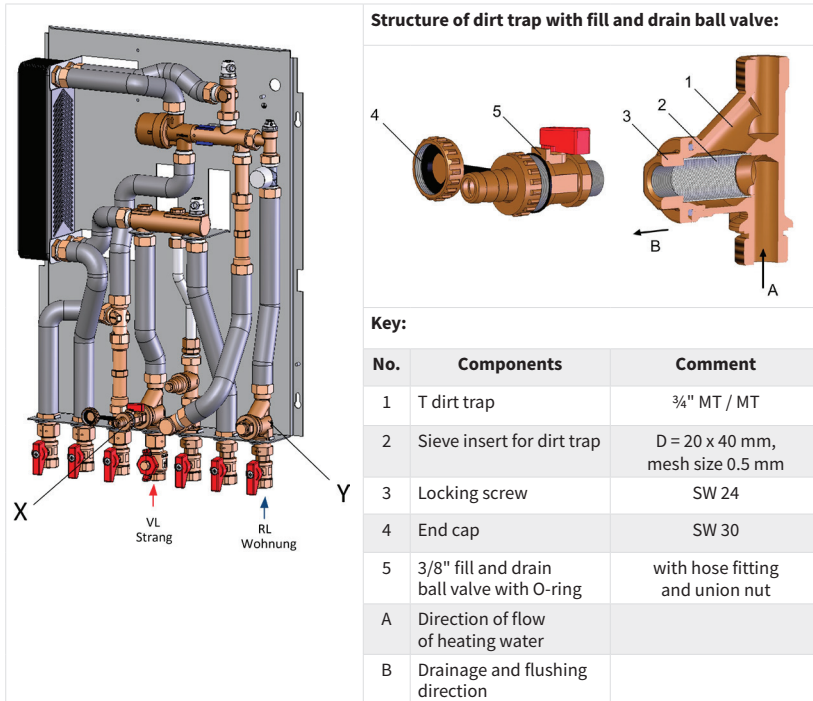

Fig.: Version with (X) and without (Y) fill and drain ball valve

5.3 Zone valve for heating circuit

The pre-adjustable zone valve in the interface station limits the hot water flow rate to the heating circuit to compensate for the higher pressure losses during the heating of the hot water. To avoid flow noise in the apartment, it is advisable to adjust the zone valve in accordance with the design documents. Note: The zone valve has a Kvs value of 1.8

As an option, an additional electric actuator can be used to switch off the domestic heating circuit (STL and room thermostat function).

Please observe the installation instructions available separately if installing an optionally available living space controller.

For valve presetting of the zone valve:

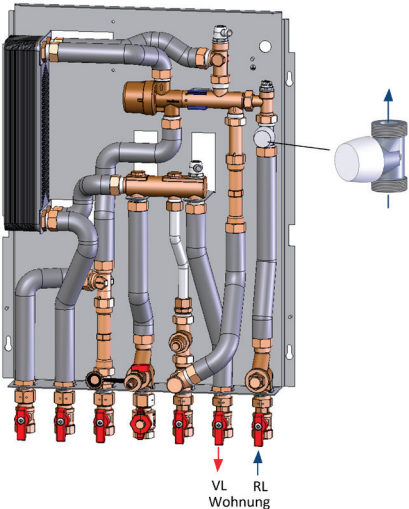
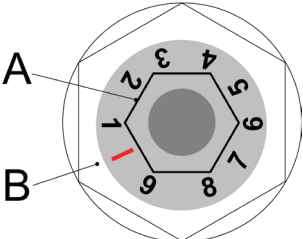
 <p>VL RL Wohnung</p>	<p>Take and adjust the setting value from the design documents according to the system for the desired heating system flow rate.</p> <p>To do this, remove the protective cap (white) from the valve and carry out the following setting steps.</p>
<p>(Item A) Carry out valve presetting with a suitable tool (e.g. size 7 open-ended spanner):</p> <ol style="list-style-type: none">1. Close the valve (by approx. 2 clockwise turns)2. Mark the new "zero point" (item B)3. Then set the desired volume flow (according to the diagram curves) using the scale 1 to 9 at the new "zero point" (turn anti-clockwise). <p>Note: Here, diagram curve 12 means turn one turn up and then set to 2.</p>	 <p>Example representations</p>

Please take account of the following guideline diagram for setting the zone valve.

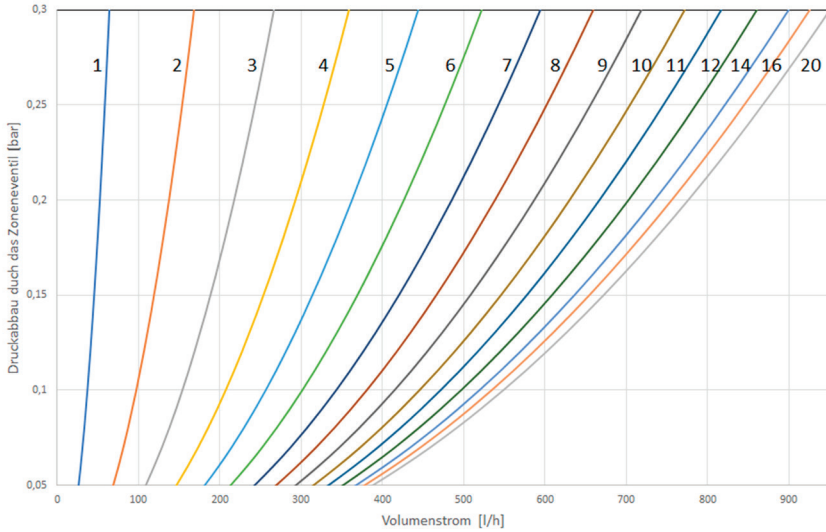
Setting curves for the zone valve:

Note:

In the case of an existing heat meter, the volume flow can also be set with the aid of the heat meter.

5.4 Differential pressure regulator (depending on variant)

The differential pressure regulator is used for hydraulic balancing, i.e. maintaining the necessary differential pressure for the hot water preparation via the station.

Technical data:

Max. permissible operating pressure:	10 bar (1000 kPa)
Max. permissible temperature:	+ 120°C
Max. differential pressure over valve:	2 - 4.5 bar (200 - 450 kPa), the greatest with low flow
Differential pressure or control range:	0.1 - 0.4 bar (10 - 40 kPa)

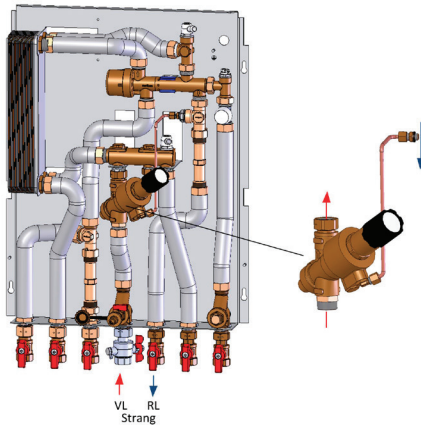

Settings:

- Remove the protective cap (black)
- Adjust the spring setting by screwing the spindle in or out with a hexagon socket wrench (6 mm).
- Screw on the protective cap

Characteristic curve diagram of the differential pressure regulator (DN20)

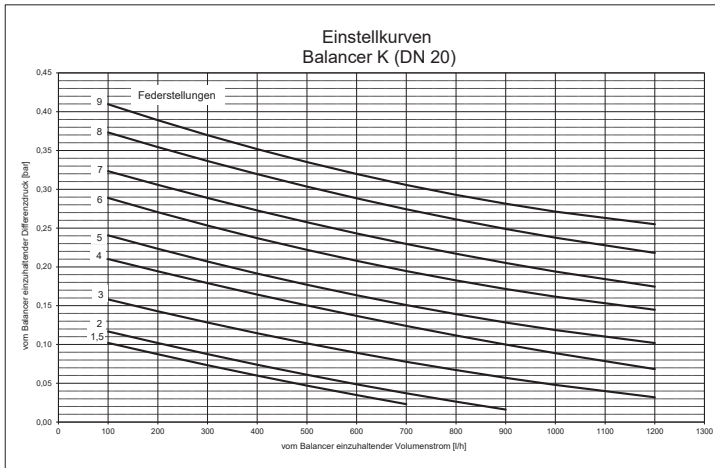

Note:

The line must be filled so that the pressure in the flow line is not considerably higher than that of the return line, otherwise the differential pressure regulator will close.

5.5 Thermostatic circulation bridge (depending on variant)

The thermostatic circulation bridge guarantees uninterrupted provision of the heating medium for water heating. The supply temperature can be continuously adjusted between 35°C and 65°C on the temperature scale. Adjust the value by screwing the spindle "X" in or out with an open-ended wrench (SW 11mm).

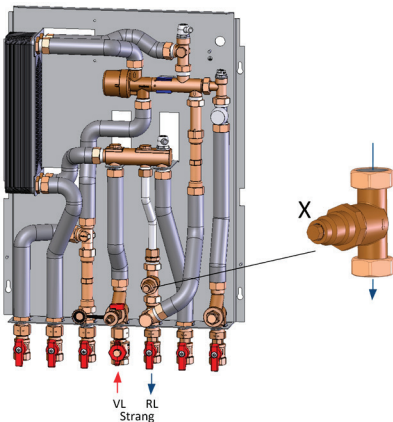

5.6 Return temperature limiter (add-on element)

The return temperature limiter "Y" restricts the return flow temperature of the dwelling heating circuit. The desired value can be set infinitely between 35 ... and 65°C on the temperature scale. Adjust the value by screwing the spindle in or out with an open-ended wrench (SW 11mm).

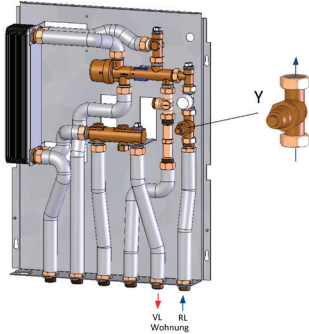

Notes:

The return temperature limiter does not replace the hydrological balance of the dwelling heating circuit and the station.

Other temperature ranges are available on request.

5.7 Thermostatic hot water mixing valve (add-on element)

The thermostatic mixing valve "Z" is used to restrict the outlet temperature or as scalding protection for the hot water preparation.

Tech. data of the mixing valve:

¾" connections, max. 10 bar, KVS value: 1.2;
adjustment range: 35 ... 60°C

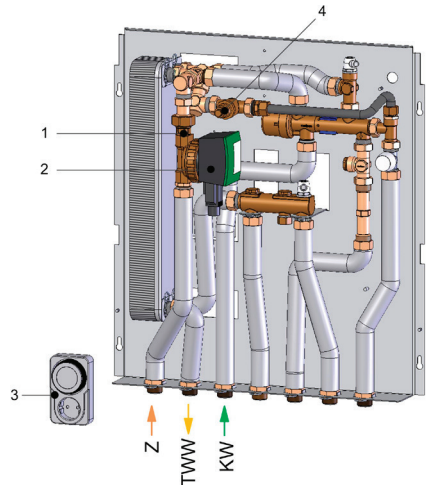

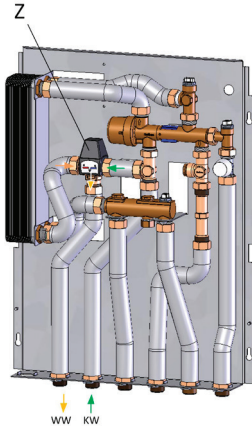

1)

2)

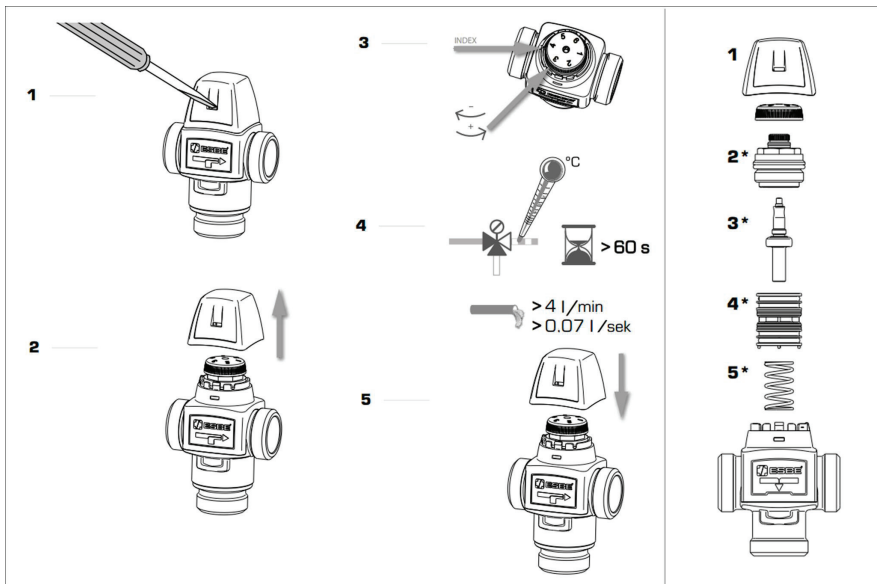

(Art No.: M45101.174)

- 1.) **Setting the water temperature** and
- 2.) **Representation of the individual parts**

5.8 Domestic water circulation system (LC 600/600+ add-on element)

The domestic water circulation system is (Z) used to provide a constant supply of domestic hot water (DHW) to the taps. Long periods of disuse should be avoided! Please ensure that you comply with the relevant technical regulations and guidelines (including for cold water CW).

With the appropriate station designs (LC600/600+) with circulation, the circulation pump (2) and a circulation bridge for 35-65°C (4) are installed at the factory.

A backflow preventer (1) is installed on the pressurised side of the circulation pump on the domestic water side in order to prevent unwanted circulation.

Notes:

The water content of the longest DHW line (without taking DWC into account) should not be greater than 3 litres. Any possible health risk (e.g. Legionella growth) versus possible energy savings must be borne in mind when configuring and operating the DWC system. The relevant applicable technical rules and valid standards must be observed and complied with.

The safety fuse of the wholesome water (sanitary) installation in a dwelling with a domestic water circulation connection must comply with DIN 1988, i.e. with a safety valve and, if necessary, an expansion vessel.

The domestic water circulation may only be put into operation once the station has been filled with domestic water (voltage supply 230 V). Otherwise the circulation function or connector must be taken out of operation in order to prevent the risk of it running dry.

Pump characteristic curve:

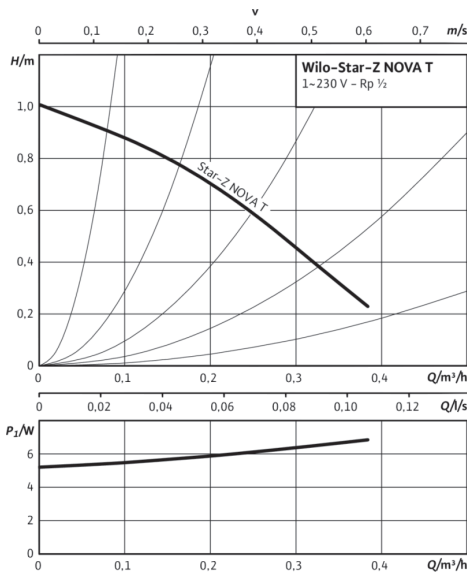

Areas of use of the DWC pump:

Media temperature = 2 to 95°C, ambient temperature = 2 to 40°C, max. 10 bar, pump protection code: IP42 The domestic water circulation pump is suitable for use in hard water up to 20°dH.

Electrical connection:

The pump must be connected on site with a separate 230 V power supply cable.

For the 230V/50 Hz electrical connection of the DWC pump: see separate instructions from the pump manufacturer!

Automatic timer:

The pump has an automatic timer which allows the switch-on and switch-off times to be adjusted.

The circulation pump with timer is set at the factory to run for 24 hours.

Recommendation: Set the pump to the corresponding circulation temperature so that the pump can cycle itself independently (to set, see the separate instructions from the pump manufacturer).

5.9 Heating circuit manifolds and mixing circuits (LC 600/600+ add-on elements)
5.9.1. LC 600+ heating circuit manifolds (3-8 HC) connected via the compact mixing circuit
Description:

- Features: Stainless steel manifold (3 - 8 heating circuits) mounted on a base plate (576 x 475 mm) for LC 600+
 Emptying, bleed valve in the flow and return line, max. 6 bar
 Flow rate limiter 0.5 - 5 l/min
 M30x1.5 valve inserts with manual adjustment caps

Connections: $\frac{3}{4}$ " thread above to the interface station, $\frac{3}{4}$ " MT Euro cone to the heating circuits

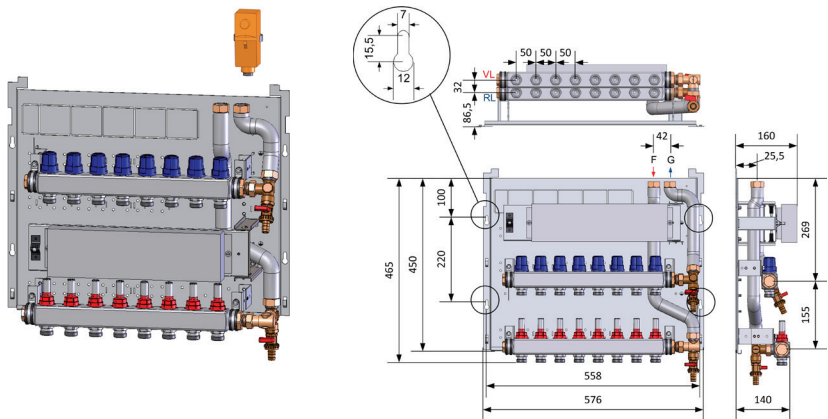
Example representation (8-way heating circuit manifold with optional pre-wired terminal strip and STM):

Overview

Manifold for:	Art. No.
3 heating circuits	M10515.3
4 heating circuits	M10515.4
5 heating circuits	M10515.5
6 heating circuits	M10515.6
7 heating circuits	M10515.7
8 heating circuits	M10515.8

5.9.2. LC 600 heating circuit manifolds (3-12 HC) connected via side connection sets

Descriptions:

- Stainless steel manifold mounted on its own base plate 792 x 485 mm (W x H)
- Installed under LC 600 stations in combination with e.g. M11100.72/.72K or M11100.73 housing and side connection set
- Incl. flow rate limiter 0.5 ... 5 l/min and M30 x 1.5 mm valve inserts with manual adjustment caps
- Connections: $\frac{3}{4}$ " thread above to the interface station, $\frac{3}{4}$ " MT Euro cone to the heating circuits

Note: any adapters required to convert to flat-sealing $\frac{3}{4}$ " MT connection for the heating circuits are not included in the delivery range!

Details:

- A)** Corresponding LC 600 stations (see Section 3)
- B)** Manifold for 3-12 heating circuits (see Section 5.9.2.1)
- C)** Side connection set (see Section 5.9.2.2)

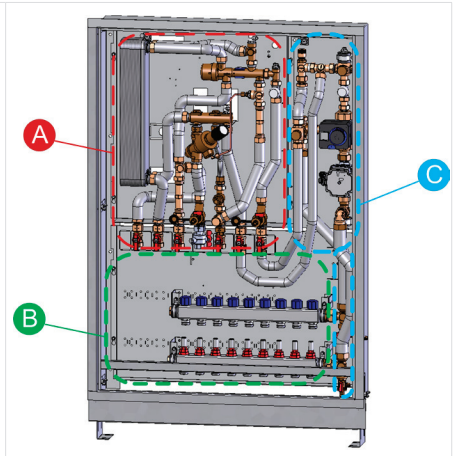

5.9.2.1 Manifold for 3-12 heating circuits

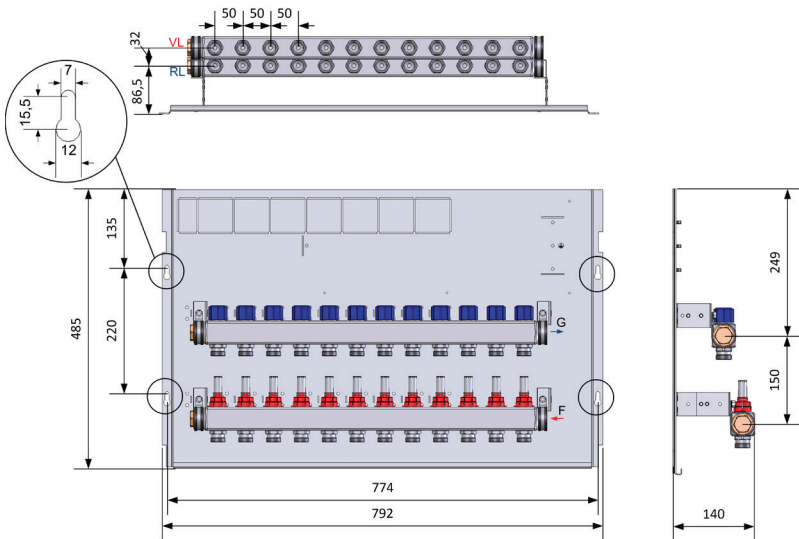

Regarding B) Example representation:

Manifold for:	Art. No.
3 heating circuits	M10512.33
4 heating circuits	M10512.34
5 heating circuits	M10512.35
6 heating circuits	M10512.36
7 heating circuits	M10512.37
8 heating circuits	M10512.38
9 heating circuits	M10512.39
10 heating circuits	M10512.40
11 heating circuits	M10512.41
12 heating circuits	M10512.42

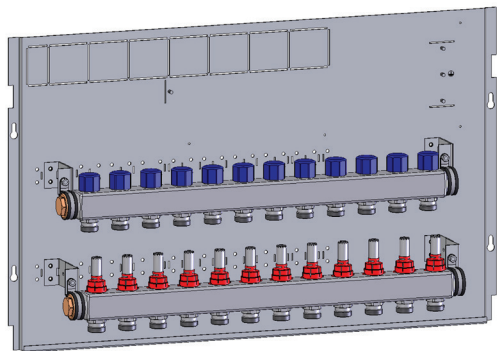

5.9.2.2 Side connection sets with pump for manifolds (3-12 HC)

Regarding C) Mixing circuit for flow line temperature control with HE pump and additional connection for a static heating circuit

Modules	M13HE, mixed HC	M27HE, mixed HC	Type M12HE, mixed HC
Description	with thermostatic valve	with controlled servomotor	with servomotor

Figures

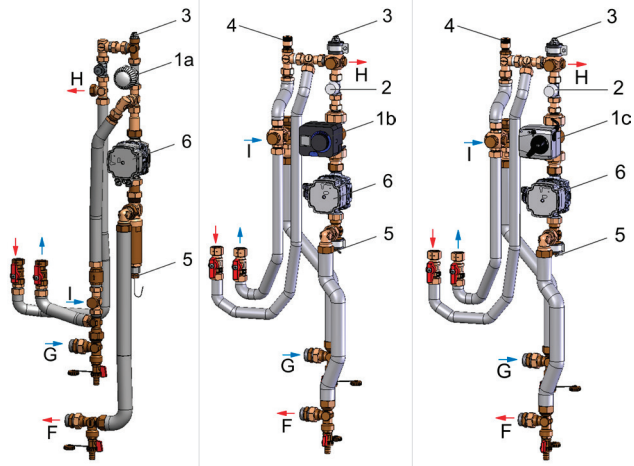

Legend for the figures

Three-way mixer with:
 1a) Thermostatic head, white, lockable, note settings below
 1b) Controlled servomotor with flow line temperature sensor (see Section 5.9.3.4)
 1c) Servomotor (see Section 5.9.3.5)
 2 - Zone valve
 3 - Automatic air vent
 4 - Secondary bypass (continuously adjustable) set to closed in the factory
 5 - Immersion sleeve for flow line temperature sensor
 6 - High-efficiency heating circuit pump, type Grundfos UPM3 hybrid 15-70, 130 mm

Dwelling heating circuit 1 (mixed): F - heating FL, G - heating RL,
 Dwelling heating circuit 2 (unmixed): H - heating FL, I - heating RL

Hydraulic diagrams

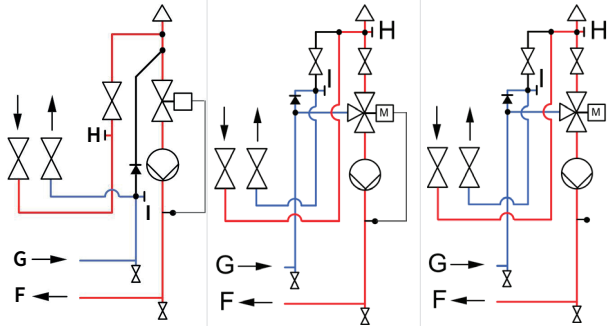

For manifolds with 3-12 heating circuits, **Art. No.:**

M10512.27

M10512.28

M10512.29

Settings for M13HE mixing circuit with thermostatically controlled valve and remote sensor
(see above, Item 1a):

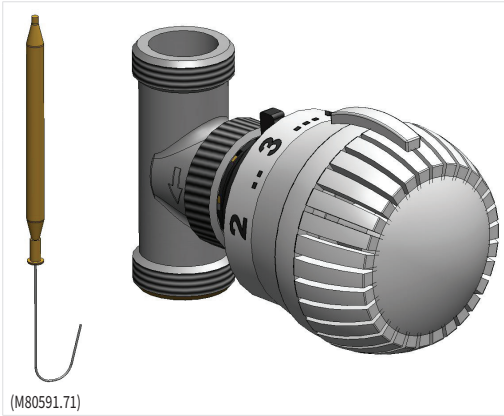

Thermostatic head setting	approx. FL temp. in [°C] of the mixed HC
2	20
3	30
4	40
5	50
6	60
7	70

Heating circuit pump (Item 6), type UPM3 hybrid 15-70, 130 mm

Technical data:

EEl: 0,20; IP44; Range of use: 2...110°C; 10 bar

Speed	P1 (W)	I1/I [A]
Min	2	0.04
Max.	52	0.52

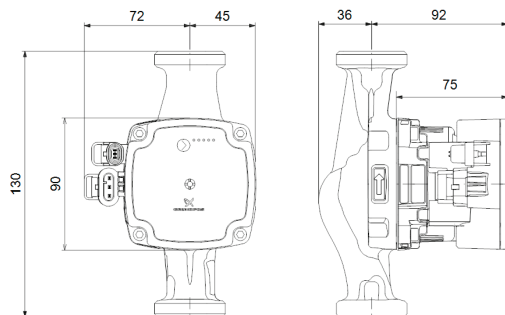

Dimensions**Electrical termination:**

230 V, 50 Hz

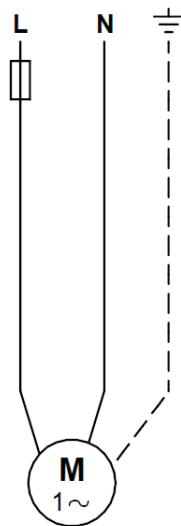

(Art No.: ME-45101.76)

Pump characteristic curve:

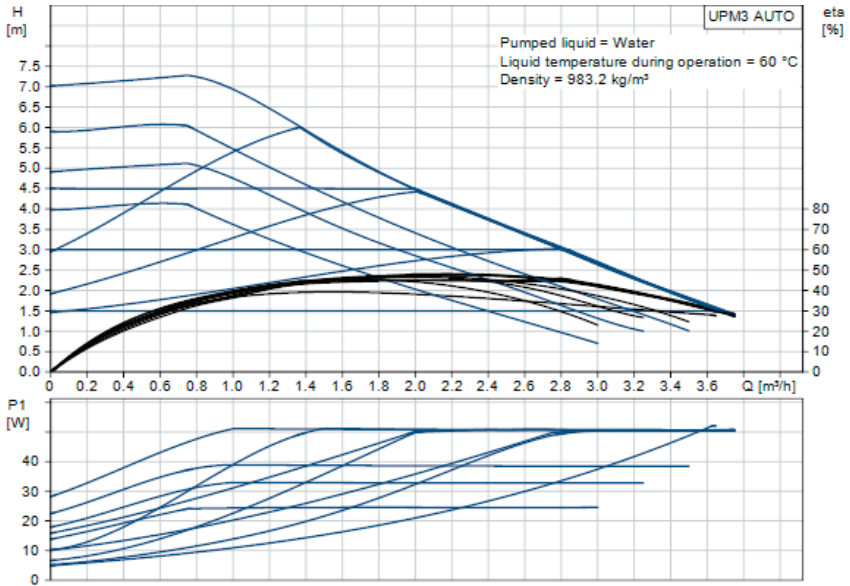

Note: The corresponding pump manufacturer specifications must also be taken into account!

5.9.3 LC 600+ compact mixing circuit groups with pump for manifolds (3-8 HC)

Overview of modules

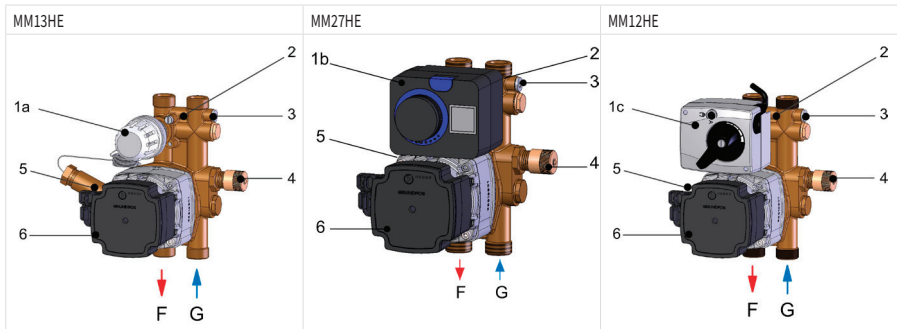

Key:

Three-way mixer with:

1a) Thermostatic head, lockable, with the following settings (see Section 5.9.3.3)

1b) Controlled servomotor with flow line temperature sensor (see Section 5.9.3.5)

1c) Servomotor (see Section 5.9.3.4)

2 - Primary bypass (low differential pressure mixing circuit)

3 - Plugs

4 - Secondary bypass (continuously adjustable)

5 - Immersion sleeve for flow line temperature sensor

6 - High efficiency heating circuit pump, type Grundfos UPM3 Auto 15-70 GGMBP (see Section 5.9.3.2)

F - Heating flow line (FL)

G - Heating return line (RL)

Installation example: LC 600+ station with possible compact mixing circuit groups and heating circuit manifolds

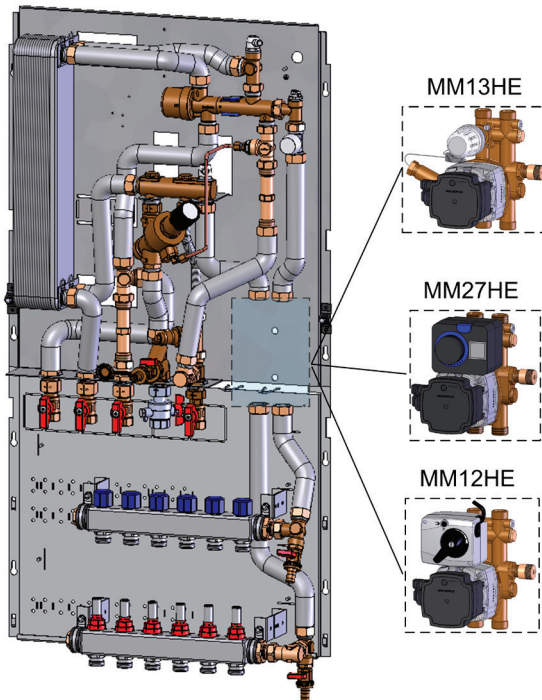

Note: example representations

5.9.3.1 Bypass (for compact mixing circuit groups)

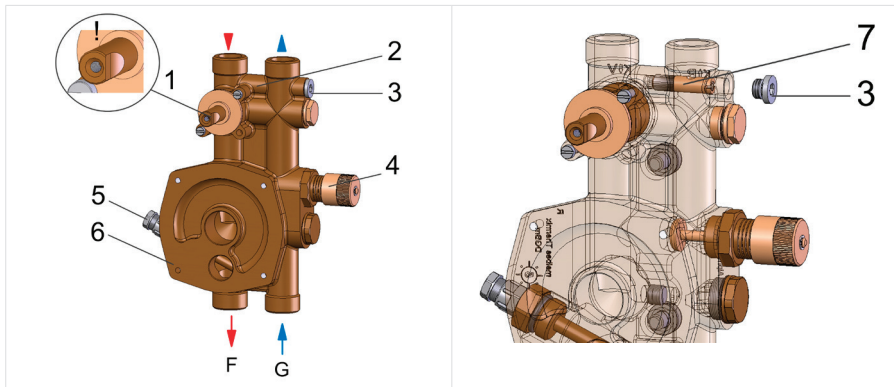

Key:

- 1) Shaft from mixing valve
(Its flattening indicates the closed path!)
- 2) Primary bypass
- 3) Plugs
- 4) Secondary bypass
- 5) Immersion sleeve for flow line temperature sensor
- 6) Connecting surface for HE pump
- 7) Threaded pin (primary bypass)

F) Heating flow line (FL)

G) Heating return line (RL)

Primary bypass (Item 2):

Non-functioning in delivered state.

To commission:

- Unscrew the plugs (3)
- Unscrew the threaded pin (7) (using a hexagon socket wrench)
- Screw the plugs (3) back in

Secondary bypass (Item 4):

Settings (constant pre-mixing):

- The bypass is set to closed in the factory.
- Information on setting it can be found in the following table (open by rotating to the left):

Open bypass (rotation)	0.5	1	1.5	2	3	4	5	6
Flow rate	30%	44%	71%	82%	92%	96%	98%	100%

5.9.3.2 Heating circuit pump, type UPM3 15-70 Auto

Electrical data: 230V, 50 Hz

EEL: 0,20; IP44; Range of use: 2...110°C; 10 bar

Speed	P1 (W)	I1/I [A]
Min	5	0.07
Max.	52	0.52

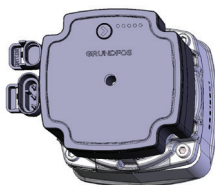

(Art No.: ME-26900.008)

Pump characteristic curve:

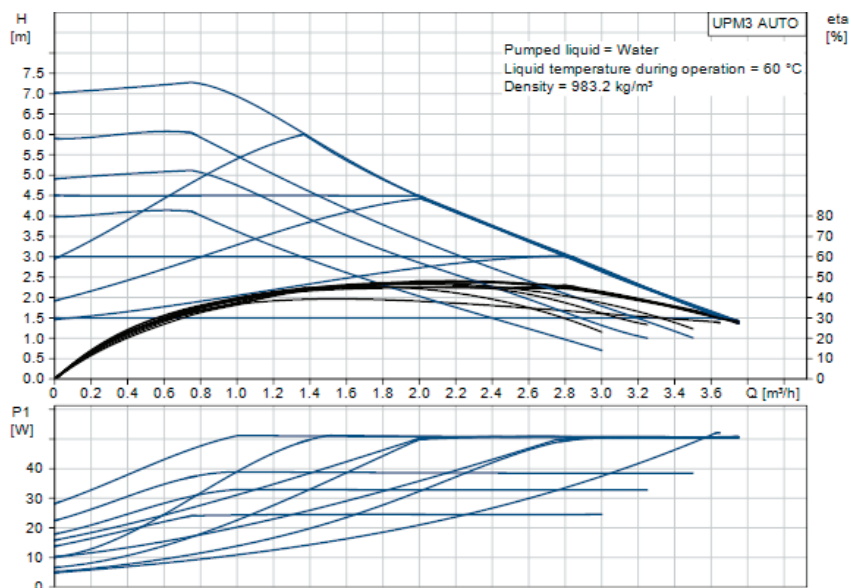

Note: The corresponding pump manufacturer specifications must also be taken into account.

5.9.3.3 Mixing circuit with thermostatic head and remote sensor (for MM13HE)

Settings:

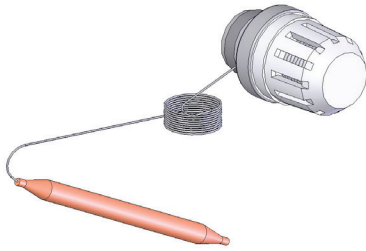

(ME-80580.14)

Thermostatic head Setting	approx. flow temperature in [°C] of the mixed heating circuit
*	25
1	30
2	35
3	40
4	45
5	50

5.9.3.4 3-point actuator (for M12HE)

Technical data:

- Grey actuator (3-point) with manual adjustment option

Nominal voltage: 230 V ~ 50 Hz
 Power consumption: 2.5 W
 Running time: 140 s, 90°
 Torque: 6 Nm
 Connection cable: 3 x 0.5 mm², approx. 2 m length

(Art No.: M66341.5)



Electrical connection diagram:

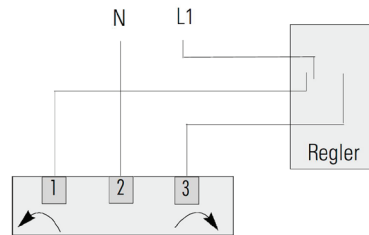

5.9.3.5 Servomotor with fixed value controller (for M27HE)

When setting the controller, ensure that the valve opens in the correct direction. An incorrect direction of rotation can lead to excessively high or low temperatures in the system and consequently to damage to the system.

When setting the controller, ensure that the minimum and maximum target temperature is set correctly. Incorrectly selected limit values for setting the target temperature lead to an incorrect target temperature setting and consequently to unwanted operation, which can cause damage to the system and harm to the user.

Each system with controller must have independent system protection in case of too-low or too-high temperatures. The controller does not have any protective function for preventing too-low or too-high temperatures in the system.

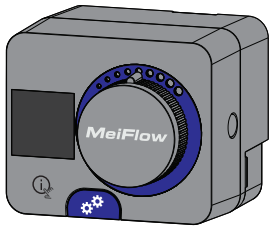

Technical data (Art. No.: M66341.37)

Torque:	6 Nm
Angle of rotation:	90 [°]
Speed of rotation:	120 s / 90 [°]
Operating mode:	3-point, PID
Supply voltage:	230V AC, 50 Hz
Max. power consumption:	3.5 VA
Temperature range:	0 ÷ 50°C
Protection code:	IP42 as per EN 60529
Protection class:	I as per EN 60730-1
Dimensions (W x L x H):	86.5 × 95 × 80.3 mm
Weight:	900 g
Colour / material:	Dark grey / PC
Battery:	CR1025 (Li-Mn) 3V
Clock accuracy:	+/-1s (24h) at 20°C

Configuration of the servomotor with temperature controller, type MeiFlow MFR3

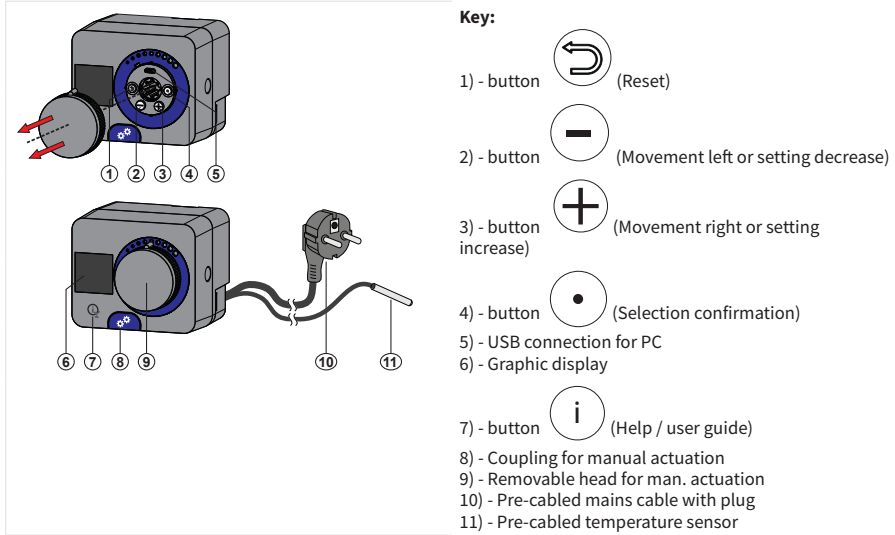

To commission the controller, and for information on display / fault displays, manual operating mode and installation and servicing work, see the current documentation for the servomotor.

Note: the safety instructions and other specifications from the servomotor manufacturer must also be observed!

5.9.4 Prewiring concepts

Prewiring for each interface station with underfloor heating circuit manifolds, incl.:

- UFH terminal strip (with protection code: IP44; protection class: II; supply voltage to the valve actuators and room thermostats 230V~ 50 Hz)
- Pump logic module (automatically switches the pump on if there is heat demand from the connected room temperature controller)
- Night-time lowering possible via channels A and B (see Section 5.9.4.2)
- Hinged retaining plate for the terminal strip (for access to all assemblies)
- Safety temperature monitor (STW) with thermal actuator
- Professional wiring and supply within the selected LC station

Variants:

Prewiring concepts	Art. No.
For use with up to 8 zones	MB-10560.09
For use with up to 10 zones	MB-10560.10

Warning:

The actuators needed in each case must be ordered separately corresponding to the number of underfloor heating circuits.

5.9.4.1 Configuration of the terminal strips

Example representation:

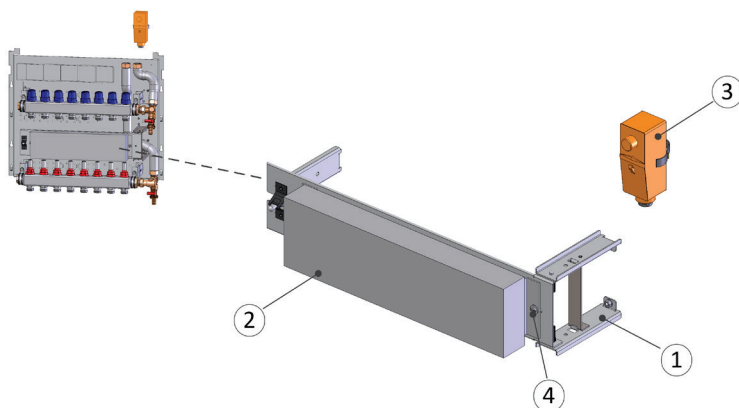

Key to configuration:

Item	Components
1	Terminal strip holder, height-adjustable
2	Controller terminal strip 230V with pump logic module, IP44 (correspondingly in each case for HC manifolds with up to max. 8 or 12 HC)
3	Contact thermostat 16 (2.5) A / 230 V installed as STM on the insulated FL pipe or HC manifold
4	Connection protective earthing using cylinder screw and shims

Note: When arranged between FL/RL manifold bars, the construction height is approx. 180 mm

5.9.4.2 Wiring plan for controlling actuators in HC manifolds

Electrical connection and wiring plan for controlling LC 600/600+ stations with optional components (such as room thermostats):

Anzahl
HZK
bis 8
bis 12

Klemmleiste
10560.962
10560.963

Verdrahtungsplan
B-00560.09
B-00560.10

Anschluss Wohnungsstation

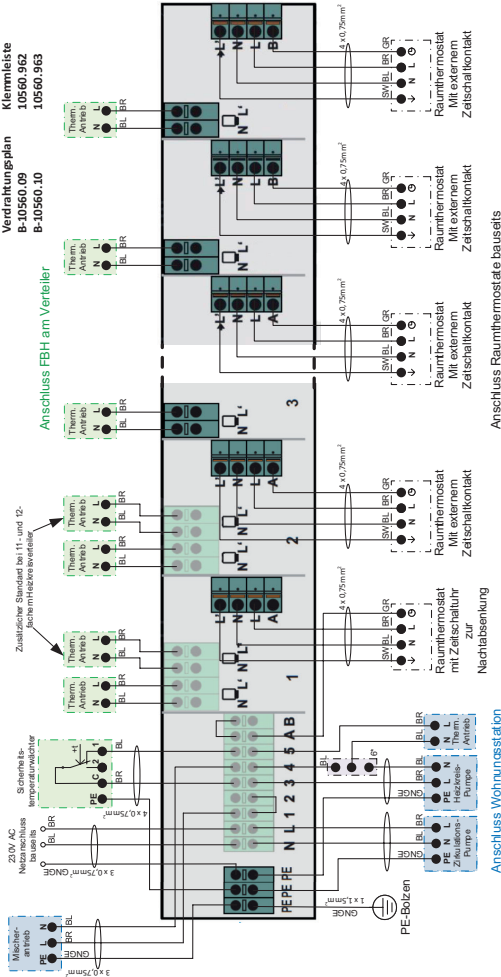

Anschluss Raumthermostate bausetts

Anschluss Wohnungsstation

Attention: Electrical connection work may only be carried out by authorised electricians!
Note the safety instructions (see Section 1)

- A: Connection of external automatic timer (channel A)
- B: Connection of external automatic timer (channel B)
- 6*) Connection terminal 3-pole (Wago Compact 221-413)

- PE: Protective conductor
N: Mains connection neutral conductor
L: Mains connection phase
- 1: internally connected with L
 - 2: Pump logic potential-free relay (contact 1)
 - 3: Pump logic potential-free relay (contact 2)
 - 4: internally connected with N
 - 5: Free contact

5.10 Additional connection for static heating circuit (LC 600+, add-on element MM28)

Configuration:

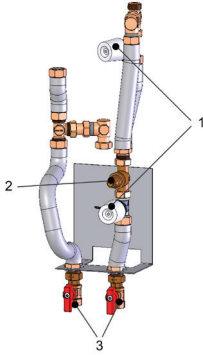

Descriptions and key:

- 1) Thermoelectric actuator 230 V (NC), closed when currentless
- 2) Return line temperature limiter (optional module MM11)
- 3) 3/4" FT ball valve x union nut

Note:

The installation depth for flush-mounted covers of min. 195 mm must be borne in mind when using the MM28 module!

When selecting the additional unmixed heating circuit in combination with the return temperature limiter module, this is positioned in the return flow of the unmixed heating circuit.

Warning! Cannot be used in combination with underfloor heating circuit manifolds M10515.3 to M10515.8

An additional zone valve for installing a room controller is already included for individual control.

Dimensions/connections:

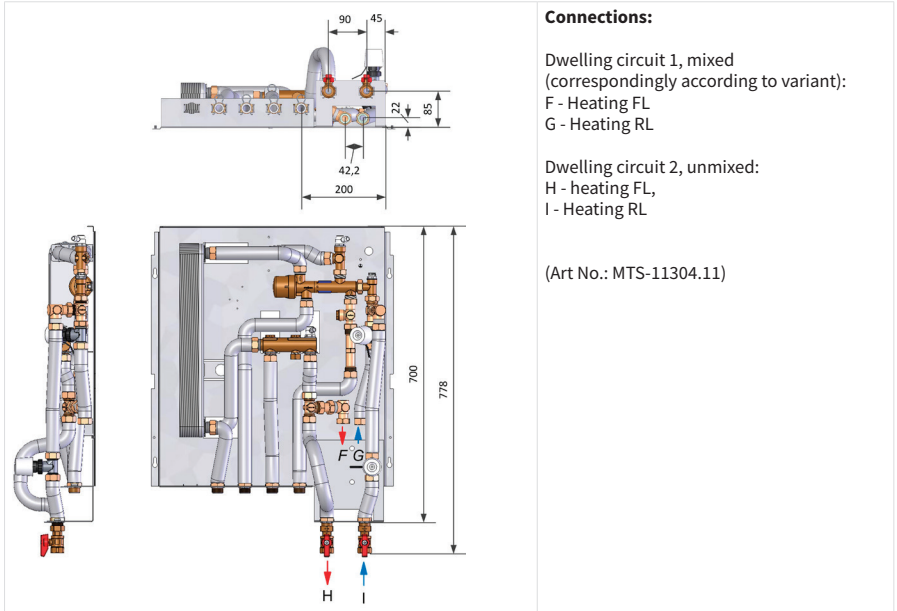

Connections:



Dwelling circuit 1, mixed
(correspondingly according to variant):
F - Heating FL
G - Heating RL

Dwelling circuit 2, unmixed:
H - heating FL,
I - Heating RL

(Art No.: MTS-11304.11)

5.11 Claddings / covers for LC stations (as optional accessories)

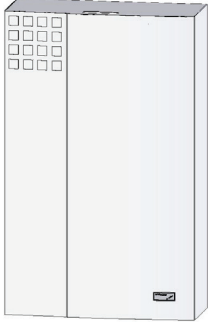
5.11.1 Overview of surface-mounted covers (SMC)

Wall-mounted	Claddings with dimensions for LC variants 500 / 600 and 600+ W x H x D in [mm]		Model in sheet metal, RAL 9016	Model for radio with plastic insert, RAL 9016	Figures
Surface-mounted covers	500	500 x 800 x 210	M11200.1	M11200.1K	
	600/ 600+	600 x 800 x 210	Without UFM: M11100.1	Without UFM: M11100.1K	
Surface-mounted covers, long model	500	500 x 1000 x 210	M11200.1L	M11200.1KL	
	600/ 600+	600 x 1330 x 210	Up to 8 HC: M11100.46	Up to 8 HC: M11100.46K	
	600	850 x 1210 x 210	Up to 12 HC: M11100.73		

5.11.2 Overview of flush-mounted covers (FMC)

	Claddings with dimensions for LC variants 500 / 600 and 600+ W x H x D in [mm] (D: from-to)		Model in sheet metal, RAL 9016	Model for radio with plastic insert, RAL 9016	Figures
Flush-mounted covers, wall-mounted	500	510 x 835 x 150-220	M11200.2	M11200.2 K	
	600/600+	610 x 835 x 150-220	Without UFM: M11100.2	Without UFM: M11100.2 K	
Flush-mounted covers, wall-mounted, long model		610 x 1175 x 150-220	Up to 8 HC: M11100.4	Up to 8 HC: M11100.4 K	
	600	845 x 1175 x 150-220	Up to 12 HC: M11100.72	Up to 12 HC: M11100.72K	
Wall-mounted, completely closed	600/600+	610 x 835 x 150-210	M11100.23	M11100.23K	
		610 x 1175 x 150-210	M11100.24	M11100.24K	
Wall-mounted, completely closed, long model	600	845 x 1175 x 150-210	M11100.25		
	Feet for FMC RAL 9016, conversion to floor-standing	500	W= 510 Height-adjustable: 100-170	M11200.21	
600/600+		W= 610 Height-adjustable: 100-170	Up to 8 HC: M11100.21		
600		W= 845 Height-adjustable: 100-170	Up to 12 HC: M11100.71		

Revision frame with door (W x H)	500	Door: 500 x 800	M10203.317	M10203.317K	
	600/600+	Door: 600 x 800	M10203.309	M10203.309K	
		Door: 600 x 1150	M10203.312	M10203.311K	

Example representations

Key for the figures: A - Door with lock; B - Door frame (depth adjustable); C - Frame
 5.11.3 Installation examples

Example with flush-mounted cover: open at bottom, wall-mounted (colour white, RAL 9016)
 5.11.3.1 FMC - long model

Structure and dimensions:

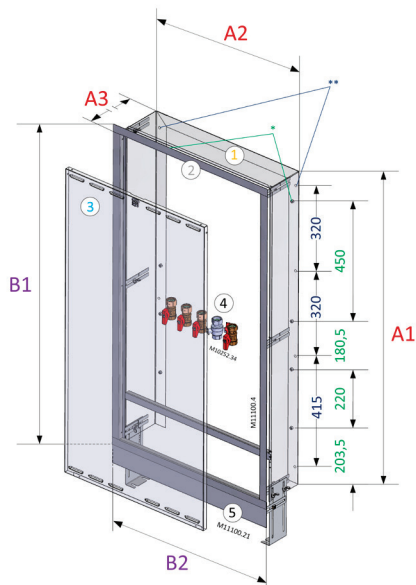

Warning!

Note the min. installation depth for e.g. HFM installed by the customer.

Example representations

Key:

(1)	Mounting frame
(2)	Revision frame (depth adjustable)
(3)	Door with lock
(4)	Ball valve set, optional (further details see Section 4.3)
(5)	Optional height-adjustable feet (100-170 mm) with cover trim
*	Holding points M6 for Logotherm station
**	Wall mounting holes diameter 3 mm

Installation dimensions A [mm]			External dimensions B [mm]	
Height A1	Width A2	Depth A3 (from-to)	Cover trim height B1	Cover trim width B2
1175	610	150-220	1202	655

5.11.3.2 FMC - wide model

Structure and dimensions:

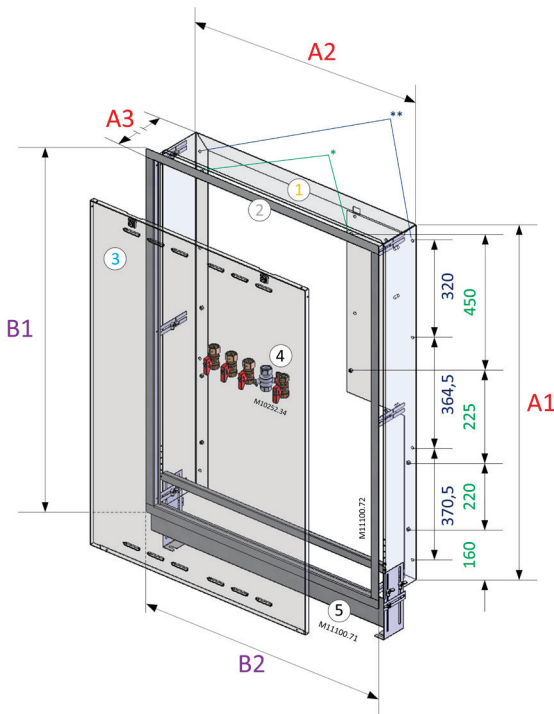

Warning!

Note the min. installation depth for e.g. HFM installed by the customer.

Key:

(1)	Mounting frame
(2)	Revision frame (depth adjustable)
(3)	Door with locks
(4)	Ball valve set, optional (further details see Section 4.3)
(5)	Optional height-adjustable feet (100-170 mm) with cover trim
*	Holding points M6 for Logotherm station
**	Wall mounting holes diameter 3 mm

Installation dimensions A [mm]			External dimensions B [mm]	
Height A1	Width A2	Depth A3 (from-to)	Cover trim height B1	Cover trim width B2
1175	845	150-220	1202	871

5.12 Configuration examples

5.12.1 Example I - Station with 9-way UFH manifold via compact mixing group with SMC

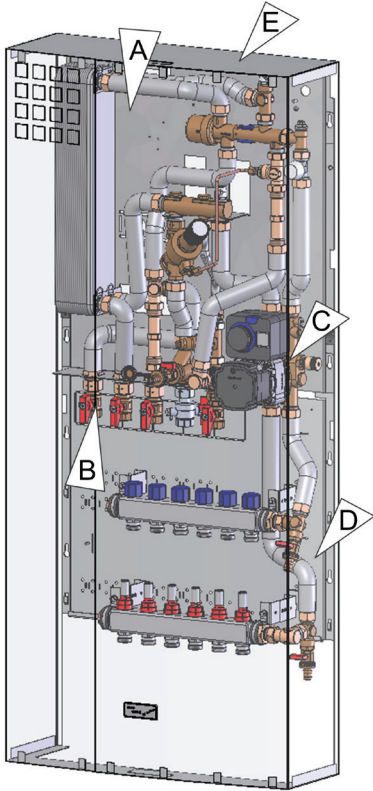

Example representations

Component list (I) or as LC complete station (M11104.6MKAP)

Item	Definitions	Art. No. (example)
A	LC 600+ as prefabricated station, 17 l/min, with copper-soldered heat exchanger	M11104.33
B	Ball valve set with 5 x DN 20 straight ball valves	M10252.34
C	MM27HE, mixed HC via controlled compact mixing group	Part of Item A
D	Underfloor heating circuit manifold for up to 6 HC	M10515.6
E	Long SMC, 600x1330x210 mm	M11100.46

5.12.2 Example II - Station with 9-way UFH manifold via side mixing group with FMC

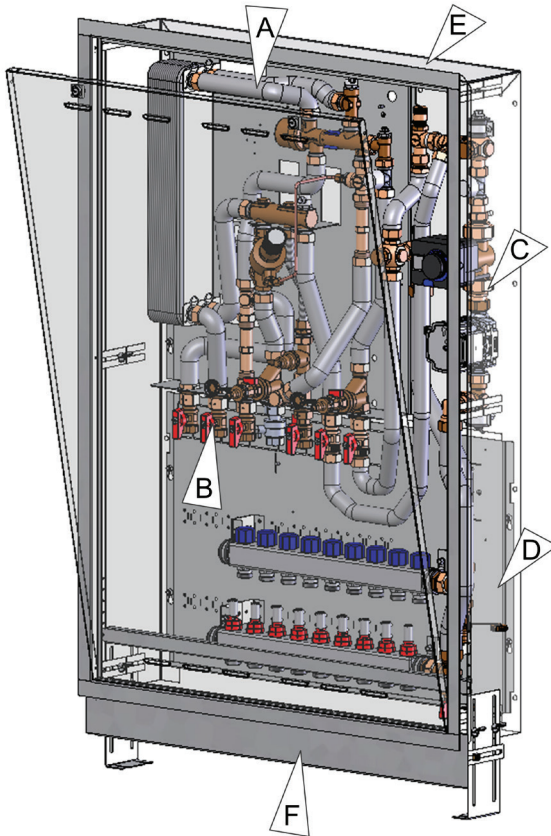

Example representations

Component list (II) or as LC complete station (M11104.9MKUP)

Item	Definitions	Art. No. (example)
A	LC 600 as prefabricated station, 17 l/min, with copper-soldered heat exchanger	M11104.21
B	Ball valve set with 5 x DN 20 straight ball valves	M10252.34
C	M27HE, mixed HC via controlled side connection group	M10512.28
D	Wide underfloor heating circuit manifold for up to 9 HC	M10512.39
E	Long, wall-mounted FMC, 845x1175x195-220 mm	M11100.72
F	Feet for FMC, floor-standing conversion, height-adjustable 100-170 mm	M11100.71

6. Commissioning

Before using our products, they must be checked for suitability for the respective planned application.

Please pay special attention to the water quality at the place of use for drinking water applications. In the case of critical drinking water qualities, please take suitable measures (e.g. water treatment) to avoid functional impairments and/or damage, e.g. corrosion damage. In particular, please check the permissible limit values, e.g. for electrical conductivity, the pH value, the local hardness level and the ammonium concentration.

You will find further information in the "Docfinder" area at: www.flamcogroup.com "Information on water quality, preventing limescale deposits, stone formation and corrosion in systems with decentralised hot water preparation".

After installation or maintenance work and before commissioning, all water lines must be connected according to the existing system design.

Ensure that all materials, tools and other equipment required for the models have been removed from the device's working area.

6.1 Flushing and filling

Note for the installer:

Heating systems must be flushed prior to commissioning in accordance with local regulations, such as DIN EN 14336, VOB ATV C DIN 18380 or VDI 2035. After the system has been filled for the first time, the recirculation pump must be left to run for about 1 hour before it can be switched off for a longer period.

Flush the system carefully before filling.

Check all joints and connections and tighten them if necessary.

Ensure all threaded joints are locked tight.

Once the system has been filled, bleed the unit and refill the heating system as required.

6.2 Initial start-up

Only commission the unit once it has been flushed, filled and a pressure test carried out.

All heating and domestic hot water installation work must be complete.

Bleed the station every so often during the commissioning process (for bleeding options: cf. chapter 4.5).

Commissioning must be carried out by a trained expert and the settings must be recorded in a log (for subsequent maintenance work).

Please also observe the instructions, benchmarks and settings set out in Section 7 for the control fittings used when commissioning.

The actuators must be connected to the power supply at all times when the system is full, especially for the pumps.

The following requirements must be met for successful commissioning:

- All components of the system are installed and assembled.
- The entire system is leak free.
- All necessary electrical connections have been made.

6.3 Seized Grundfos pumps, type UPM3

Counter-measures for a seized pump:

Should the pump be seized after a period of disuse and fail to start, the status indicator LED 1 = red and LED 5 = yellow will be displayed. The pump will make repeated autonomous attempts to start electronically with maximum torque for a few seconds.

Especially during / after initial filling of the system, freedom from oxygen (air) in the system must be ensured.

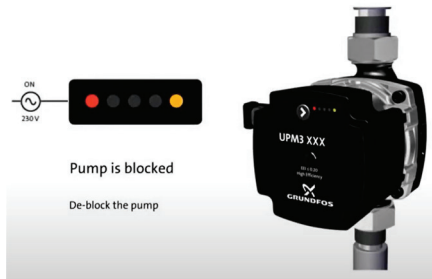

Notes:

Downtimes should generally be avoided.
 (Magnetic) Dirt and air separators must be installed properly in the system so that they work correctly.
 Freedom from oxygen (air) in the system must be constantly ensured.
 The medium used must always correspond to VDI 2035.

If the problem persists, the following manual steps can also be taken:

In this case, please use the appropriate Phillips screwdriver, e.g. Phillips No.2, and insert it into the front opening in the middle of the pump (see figures). Then press and rotate the piston briefly in both directions with the aid of the screwdriver.

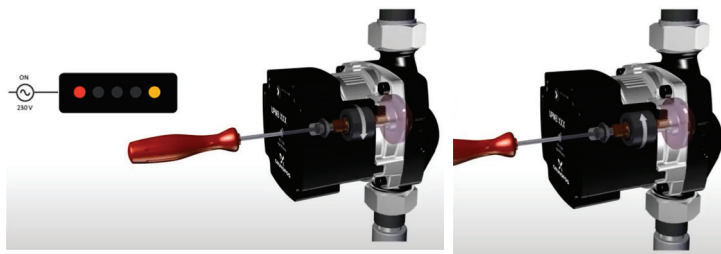

The pump should then start and run again (see also the corresponding LED display).

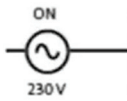

Note:

If the pump cannot be restored with this measure, the piston slips through (protection mechanism). It cannot be released and the pump will need to be repaired. -> Directly release the impeller (switch the pump off) or replace it.

The separate documentation from the pump manufacturer must also be taken into account.

7. Maintenance and service

Inspection, maintenance and service work on the Heat Interface Unit and heating system must be carried out and documented (in accordance with the relevant inspection guidelines) by a trained expert (installation company or Flamco customer service).

The condition of parts must be checked and these must be replaced if necessary. The Heat Interface Units must be checked regularly for leaks.

During maintenance work, the safety instructions and residual dangers (see Section 1) must be observed! For recommissioning, please observe the points in Section 6.

When using nitrite-free anti-freeze and corrosion protection agents with an ethylene glycol base, please pay close attention to the manufacturer's documentation, particularly with respect to the concentration and specific additives.

Different water qualities and degrees of hardness can also influence the service life of individual components of devices. Therefore, regular inspection and maintenance (according to current technical rules) should be carried out annually to maintain the system's efficiency and functional safety.

If you have any questions, please contact your installation company or Flamco customer service.

7.1 Information regarding domestic water hardness

The propensity for natural water to form limescale deposits depends, among other things, on various factors such as the concentration of calcium and magnesium salts, the pH value and the temperature.

If what is known as the lime-carbonic acid balance has been disturbed by an increase in the pH value and/or the temperature, the calcium carbonate precipitates in the form of calcite crystals.

The applicable standards and corresponding technical regulations (e.g. DIN and DVGW) must therefore be observed.

Note:

Request a water analysis from the local utility companies for testing in the event of known regional risks or contested water quality.

Propensity for scaling guidelines as per VDI 2035

Hardness ranges	Millimoles of calcium carbonate/litre	Degree of hardness in °dH	Domestic water temperatures		
			< 60°C	60 - 70°C	> 70°C
Soft	< 1.5	< 8.4	Low	Low	Low
Medium	1.5 – 2.5	8.4 - 14	Low	Low	Medium
Hard	> 2.5	> 14	Low	Medium	High

7.2 Maintenance checklist

Work to be carried out during annual maintenance

(by the specialist installer or factory customer service)

1. Visual inspection *

			Completed and OK?
1.	Proportional controller	- Check the control openings for leaks and limescale deposits	
2.	Screw connections and fittings	- Leak-tightness check	
3.	Heat exchanger	- Leak-tightness check	
4.	Electrical wiring	- Check the electrical wiring for abnormalities (e.g. damaged cable sheathing, loose plug connections, etc.)	
5.	Potential equalisation	- Check whether the potential equalisation is connected.	

* Should the visual inspection reveal the presence of leaks or deposits on screwed or connecting parts or entire components (e.g. the PF controllers at the control openings), the component(s) or, in the case of screwed connections, the seal or seal set must be replaced immediately. Note: Spare parts set for PF controller (3-way) with seals → Art No.: ME-10240

2. Function check

			Completed and OK?
1.	Dirt trap	- Check and clean the sieve insert	
2.	Shut-off valves	- Check functionality and operability; replace if defective	
3.	Zone valve	- Check the functionality of the valve tappet; replace if defective	
4.	Closure check on the proportional controller	- After the hot water is drawn off, the heat exchanger must cool down (in closed dwelling heating circuits, the flow rate menu item on the heat meter must indicate no flow)	
5.	Flow line temperature for hot water preparation	- Temperature according to specifications (cf. commissioning protocol)	
6.	Flow rate for domestic hot water preparation	- Flow rate according to specifications (cf. commissioning protocol)	
7.	Circulation bridge	- After the DHW draw-off is finished, the primary RL must remain cold	
		If the desired values under points 5 and 6 are not achieved despite the work being carried out as set out in points 1 to 4, the mains hydraulics must be checked. Please contact your responsible system operator regarding this.	

3. op = optional (not integrated into all devices)

			Completed and OK?
1.	Heating circuit pump (op)	Function check (cf. manufacturer's instructions)	
2.	Thermostatic valve with flow line temperature setting (op)	Function check and check of the correct setting (cf. commissioning protocol)	
3.	Differential pressure regulator (op)	Function check and check of the correct setting (cf. commissioning protocol)	
4.	Return flow temperature limiter (op)	Function check and check of the correct setting (cf. commissioning protocol)	

4. Parameter check

			Value
1.	Domestic water heating:	40 K (from 10° to 50°C)	
2.	Flow line temperature (heating primary):	65°C	
3.	Flow line flow rate (heating primary):	Heat exchanger; domestic water - hot 750 l/h, 24 plates, short design; 12 l/min 850 l/h, 20 plates, long design; 15 l/min 920 l/h, 30 plates, long design; 17 l/min	

Warning:

Guideline parameters for complete stations and element systems may vary, depending on the device type present or system conditions required.

8. Troubleshooting and remedying possible faults

The following overview is intended to help with the location of the causes of faults:

1. Check shut-offs
2. Check the voltage supply to pumps and servomotors
3. Check there is no trapped air
4. Check flow rate (DW and heating), media pressure and temperatures
5. Check the dirt trap at the entrance to the device
6. Check the cold water throttle / flow rate limiter for the domestic water
7. Check the functionality of all components
8. Check the function and installation of the backflow preventer and pump (if fitted)

9. Layout diagrams

The following plate heat exchanger allocations apply to the diagrams:

Product designation previously	LogoComfort stations	Type PWT	Spare part No.
12 L/min – 35 kW	S-Line	E8x24	ME-10230.5
17 L/min – 46 kW	M-Line	WP24-30	ME-10232.58

Pressure loss diagram for primary via PHE for the heating water preparation *

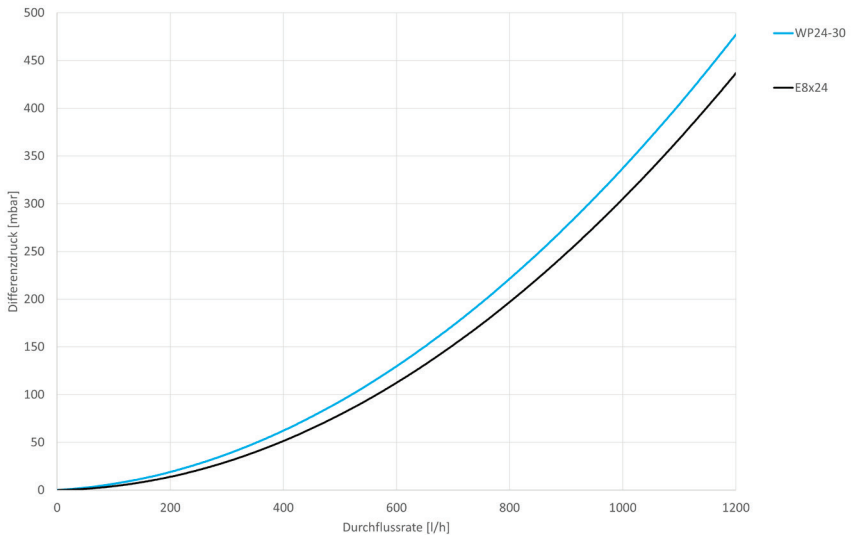

* Adapter for heat meters

Pressure loss diagram primary heating circuit*

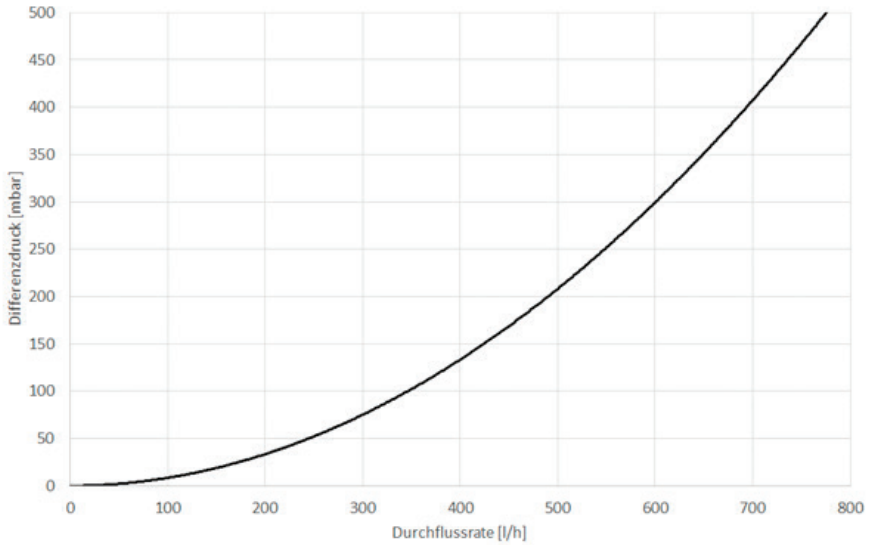

Pressure loss diagram secondary for the hot water preparation *

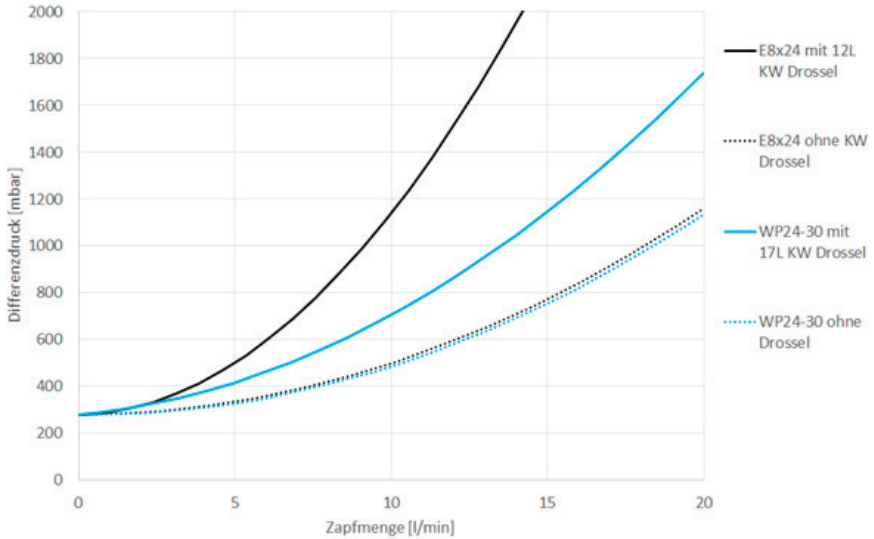

10. Decommissioning, dismantling, disposal, environmental protection and disposal of electrical and electronic equipment

During dismantling, the safety instructions and residual dangers mentioned (see Section 1) must be observed!

Removal and disposal:

Removal and disposal of the device should only be carried out by suitable trained experts. When disposing of the auxiliary and operating materials, always observe the specifications in the safety data sheets, which must be provided by the suppliers of the auxiliary and operating materials. No environmental damage must be caused during disposal. If the device is intended for scrapping, care must be taken to ensure that the individual components are of the correct type when disposing of them. It is necessary to check which way the materials can be recycled properly.

Information according to the Electrical and Electronic Equipment Act (ElektroG)*:



Disposal of electrical and electronic equipment

The "crossed-out wheeled bin" symbol means that you are legally obliged to dispose of these devices separately from unsorted municipal waste. Disposal via household waste, such as the residual waste bin or the yellow bin, is prohibited. Avoid misdirected waste by disposing of it correctly at special collection and return points. As a matter of principle, waste prevention measures take priority over waste management measures. Waste prevention measures for electrical and electronic equipment include, in particular, extending their service life by repairing defective equipment and selling functioning used equipment instead of sending it for disposal.

- Options for returning old equipment

Owners of old equipment can return it free of charge within the framework of the services for returning or collecting old devices set up and provided by public waste management authorities. In addition, returns are also possible to distributors under certain conditions.

The distributor must take back the device free of charge when a new device of the same type is purchased (1:1 take-back). There is also the possibility to return old devices to the distributor free of charge if the external dimensions do not exceed 25 centimetres and the return is limited to three old devices per type of device (0:1 take-back).

Retail: Distributors who have a sales area for electrical and electronic equipment of at least 400 square metres are obliged to take back old electronic equipment. Food retailers with a total sales area of at least 800 square metres and who, several times in a calendar year or on a permanent basis, also offer electrical and electronic equipment and make it available on the market are also obliged to take back used equipment.

Distance selling market: Distributors who sell their products using means of distance communication are obliged to take back old devices if the storage and dispatch areas for electrical and electronic equipment are at least 400 m².

- Removal of batteries and bulbs

If the products contain batteries and rechargeable batteries or bulbs that can be removed from the old device without destroying it, these must be removed before disposal and disposed of separately as batteries or bulbs.

- Data protection

We would like to point out to all end users of electrical and electronic equipment that you are responsible for deleting personal data on the electrical and electronic equipment to be disposed of.

*Please observe the country-specific national implementation of the European WEEE Directive 2012/19/EU on waste electrical and electronic equipment that is currently in force.

Manufacturer:

Meibes System-Technik GmbH

Ringstrasse 18

D-04827 Gerichshain

Germany

+49 (0) 342 927 130

info@flamco.de

www.flamcogroup.com

man_logocomfort_24002.800_ENG_2023-03

Copyright Flamco B.V., Almere, The Netherlands. No part of this publication may be reproduced or made public in any way without the express permission and acknowledgement of the source. The data listed applies exclusively to Flamco products. Flamco B.V. accepts no liability for the incorrect use, application or interpretation of the technical data. Flamco B.V. reserves the right to make technical modifications.